

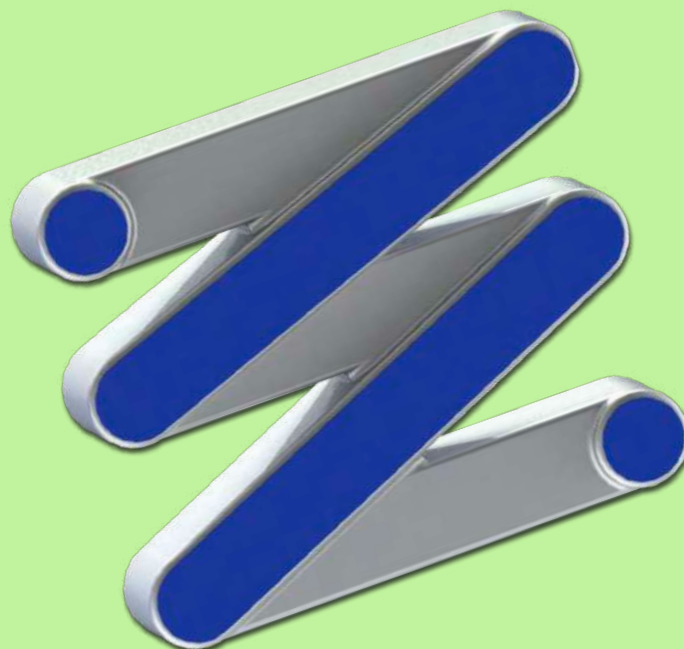

*SENOR Aisladores Acústicos



SENOR

ACOUSTIC Ceiling & Dry lining

FTD NIVEL 47



New

Patented

P.T. 201531558(6)

Manufacturer of **ANTIVIBRATION** systems



FTD NIVEL 47

A clip specially designed for
ACOUSTIC LIGHTWEIGHT CEILING in
small spaces

ISO 9001:2015



ACOUSTIC Ceiling

FTD NIVEL 47 model

The **THINNEST CLIP** for small spaces.

The **NEW** acoustic damper **FTD/NIVEL 47** is a unique isolator that stands out for its simplicity. It allows isolating and separating acoustic ceiling/ wall lining systems using profiles that act as a structure to hold laminated plasterboards, such as **F-530/PLACOSA, MAESTRA 4717/ KNAUF, TC-47/PLADUR**. It is capable by itself of reducing space to a minimum, with amazing **ALREADY TESTED** results. It has the advantage of correcting imperfections that may present the different facings, providing quality and performance to the different finishes.

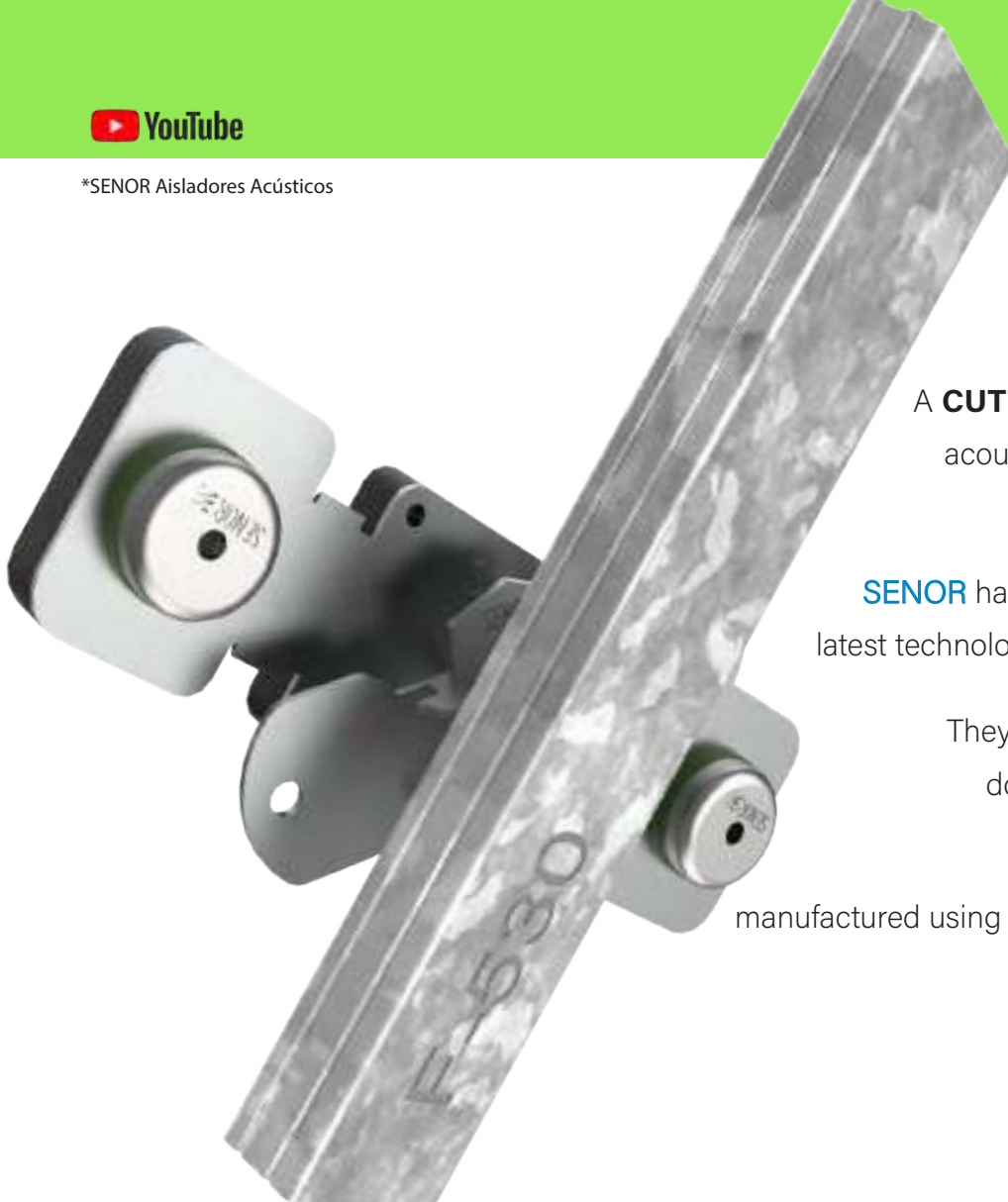

Introduction

FTD NIVEL 47 model

A **CUTTING-EDGE** product for installing acoustic ceiling and dry lining systems, making the most of tight spaces.

SENOR has made it possible by applying the latest technologies in the **vibro-acoustic** sector.

They are first generation dampers with double fixing to wall, **consisting of:**

Double acoustic core, manufactured using a renewed **polymer** that provides a higher performance to the clip.

New

Patented

P.T. 201531558(6)

The **TC 4/GPN** polymer presents a higher damping factor as well as a high degree of vibration isolation in the range of low, medium and high **frequencies Hz**. It also provides improvements in its internal mechanical properties and an acoustic performance increase of **>10%**.





A clip specially designed for
ACOUSTIC CEILING & DRY LINING

MAIN Features

The **NEW FTD/NIVEL 47** acoustic support incorporates a leveling accessory that allows to correct several centimeters placed on site. In addition, it incorporates a quick catch called "**CLIP STOP**", providing this way quality and performance to the different finishes (**We are the only ones who can manufacture it**).

A BEC-10 rubber sheet: it is a micro cellular acoustic foam made of **CAU EPDM 130 RE-42** that allows a better settlement of the clip on the wall, absorbing any small imperfection that the original facing may present, in addition to provide an optimal performance in the **mid/high frequency range (HZ)**.

New
Patented
P.T. 201531558(6)



A System: "CAU EPDM 130 RE-42"

Loads between **3-25 kg**.

Resonance Frequency **7 to 15Hz**.

B TC 4/GPN: a renewed polymer with a protruding neck, it prevents the possible contact between the set screw (**F**) and the metallic components (**C** y **E**). In addition, it provides a perfect settlement and an optimal performance in the **mid/high frequency range (Hz)**.

B System: "TC-4/GPN"

Loads between **5-25 kg**.

Resonance Frequency 7 to 15Hz.

C Bowl-shaped leveling piece:

manufactured with **DC04** deep-drawn steel according to **EN 10131** steel standard and an edge thickness of 1.5 mm.

This design allows to increase the mechanical resistance of the piece and guarantee the fixing process.

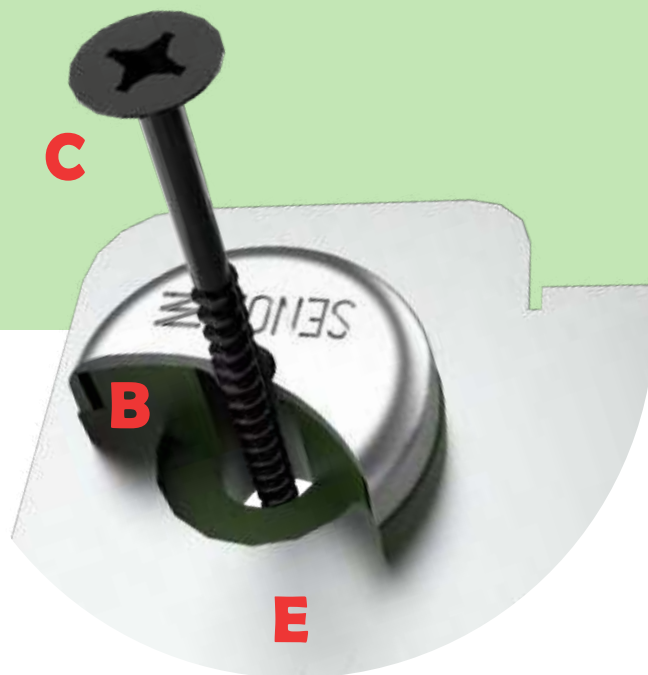

D ACC NIVEL: using this simple **clip** the metal channel remains fixed. Screws are a thing of the past. Innovation is assured by **SEÑOR** and its **NOVELTY: FTD/NIVEL 47**. Swift and security, especially in small spaces, are already **possible!**

E FTD NIVEL 47 Wall mounting plate (E): made of **Dx54d + Z140** high performance galvanized steel with an edge thickness of **1.5** millimetres. It provides rigidity to the system and axial compression in both directions to the elastic components of the product.



A clip specially designed for
ACOUSTIC CEILING & DRY LINING

*SENOR Aisladores Acústicos

F SAFETY DEVICE:

Formed by a central steel shaft (**Screw**) and a metallic circular support (**CN**). In case of fire the polymer will vanish, but the mechanical fixation will remain in place fulfilling its function.

System registered in the Spanish Patent and Trademarks Office

A clip specially designed for
ACOUSTIC CEILING & DRY LINING

New
Patented
P.T. 201531558(6)

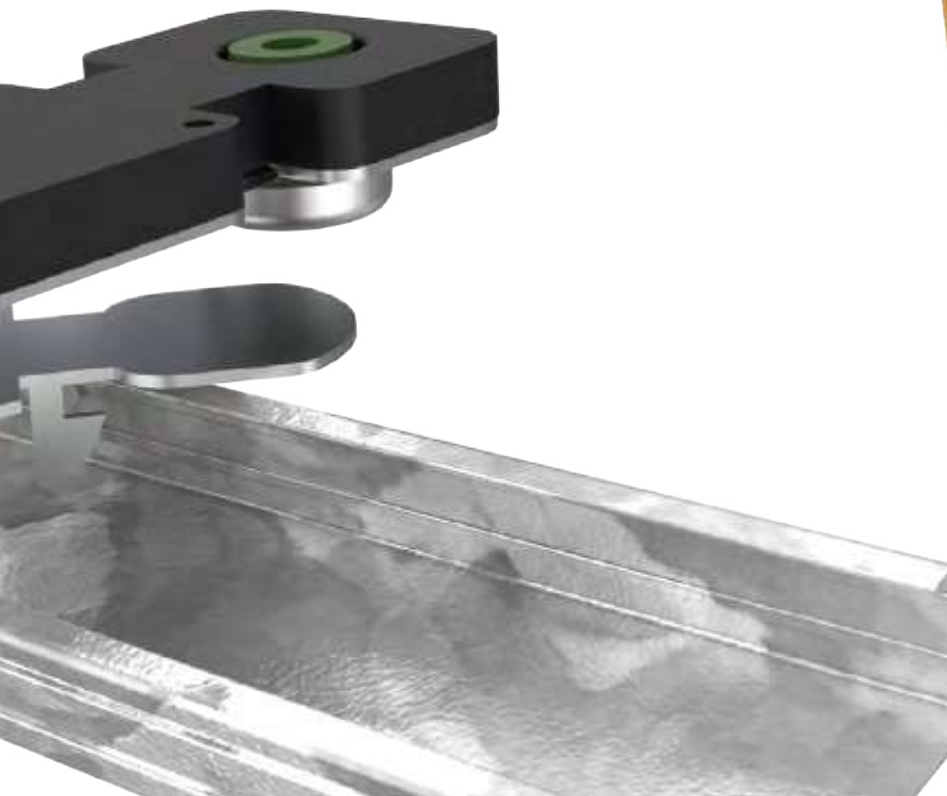

LABORATORY Tests. UNE-EN ISO 10846-1:2009

Acoustics and vibrations. Laboratory measurement of vibro-acoustic transfer properties of the elastic elements.

IMPACT testing machine



Foto **ENSAYO.**



*SENOR Aisladores Acústicos

Patented

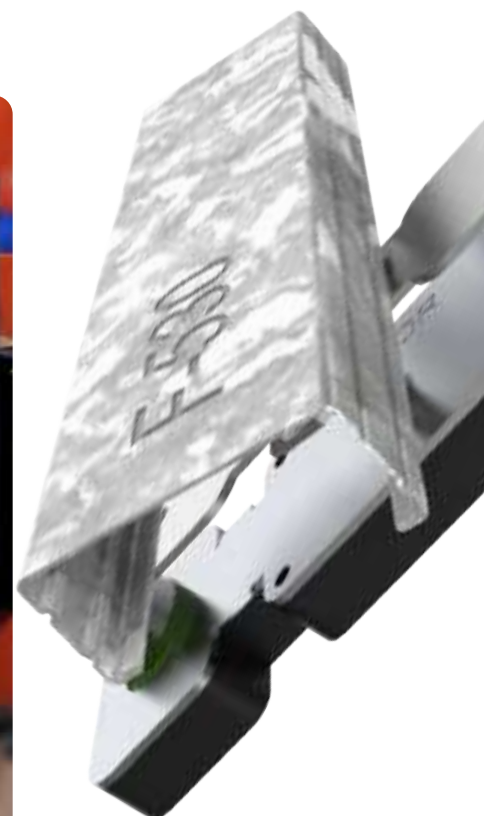
P.T. 201531558(6)

Results **OBTAINED**

Máquina de ensayo

Volver al inicio...

FTD NIVEL 47(2020)
1

Receta

E.LABORATORIO P.TRANSFERENCIA/UNE-EN ISO 10846
realizada en Máquina C

Posición [90,543 mm]

▼ -3,782 mm ● -7,460 mm ▲ 11,027 mm

Fuerza [5,00 Kg ... 25,00 Kg]

▼ 3,00 Kg ● 12,88 Kg ▲ 24,40 Kg

Velocidad [0,030 mm/s]

▼ -0,150 mm/s ● -0,013 mm/s ▲ 0,001 mm/s

Frecuencia [15,00 Hz ... 80,00 Hz]

▼ 15,00 Hz ● 40,05 Hz ▲ 50,00 Hz

Vibración atenuada [Oscilación de 10,00 mm]

▼ -73,7% ● 95,2% ▲ 97,7%

▼ mínimo ● media ▲ máximo

Frecuencia Natural Obtenida [Según deformación mm]

▼ 11,95 Hz ● 8,55 Hz ▲ 7,38 Hz

Jefe de Laboratorio	Responsable de Ensayo
David Muñoz López	Manuel Montoro Muñoz

- Los resultados del presente informe conciernen, única y exclusivamente, a las muestras sometidas a ensayo.

- Queda totalmente prohibida la reproducción parcial del presente documento, salvo consentimiento escrito de **SENOR**.

09:17 ciclo 3.576.040 Kg [Print] [Zoom]

Posición
-9,494 mm

Fuerza
17,70 Kg

Velocidad
-0,001 mm/s

Frecuencia
30,54 Hz

Vibración atenuada
92,7 %

Recibida 1,9 mm/s
Emitida 26,1 mm/s

Frecuencia Natural Obtenida [Según deformación mm]

● 7,95 Hz

1X 15:04:11 28 sept. 2020

LABORATORY Tests. UNE-EN ISO 10846-1:2009

Acoustics and vibrations. Laboratory measurement of vibro-acoustic transfer properties of the elastic elements.

"GRAPH 1"

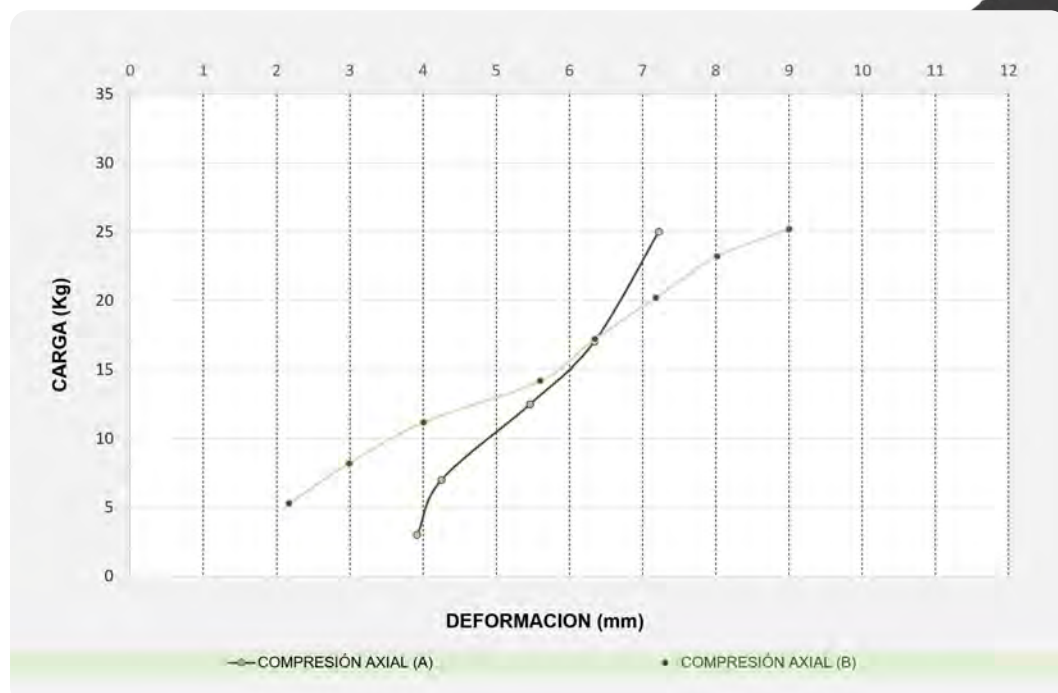

"GRAPH 2"

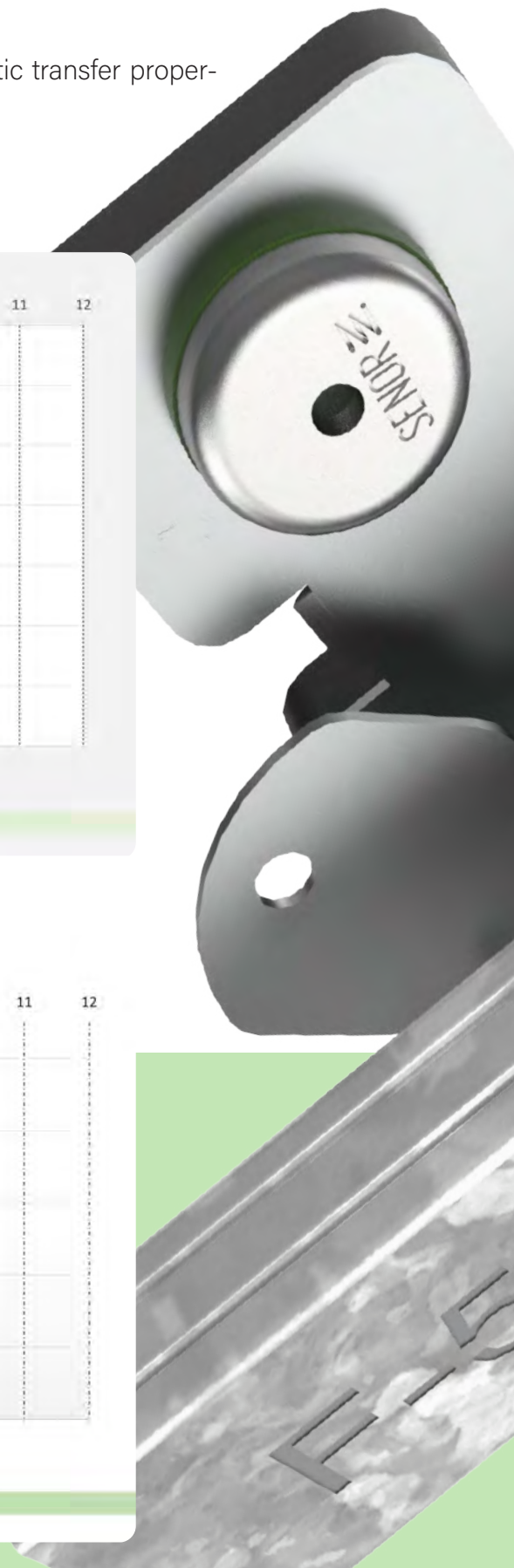
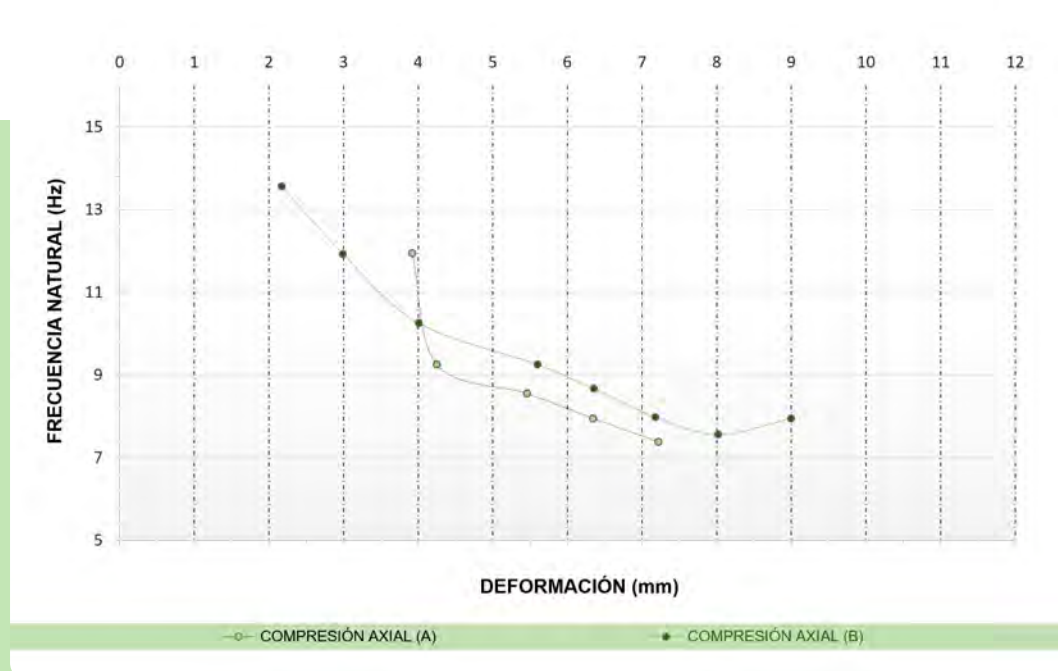

A clip specially designed for ACOUSTIC CEILING & DRY LINING

"GRAPH 3"

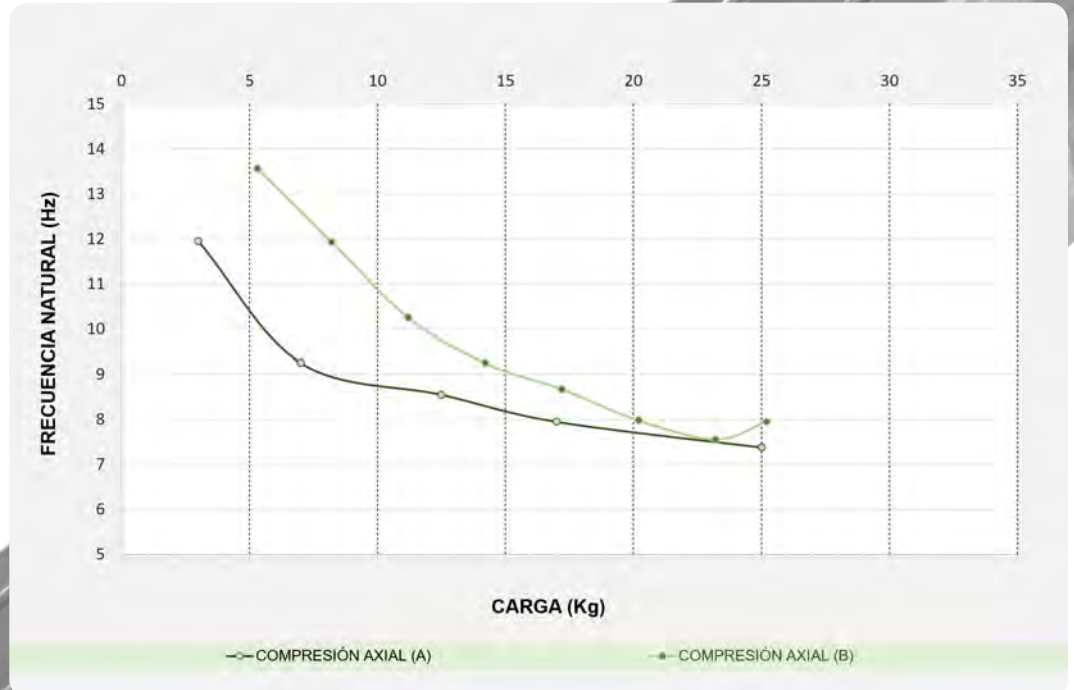

FTD NIVEL 47

New

Patented

P.T. 201531558(6)

A clip specially designed for
ACOUSTIC CEILING & DRY LINING

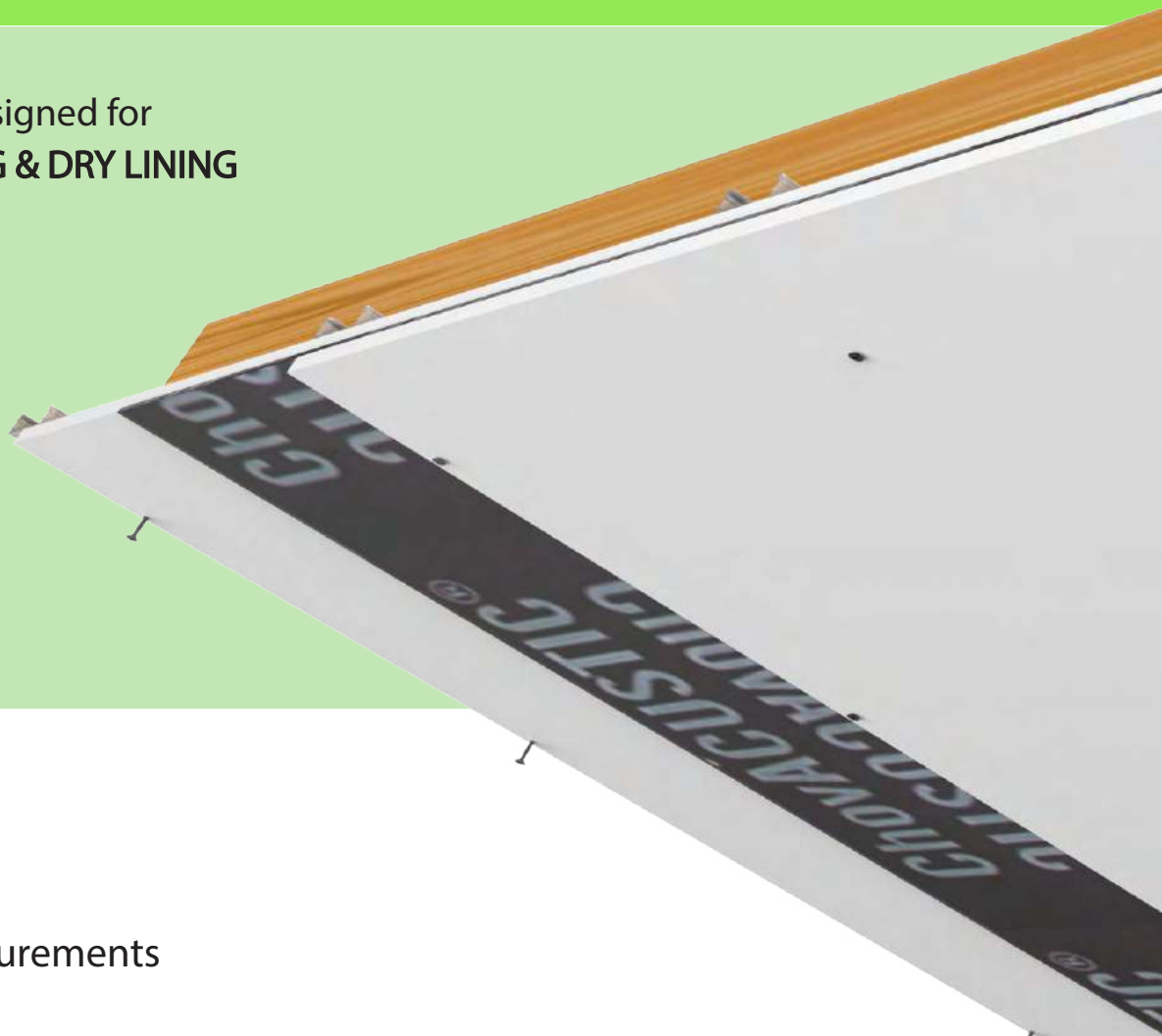

PRODUCT measurements

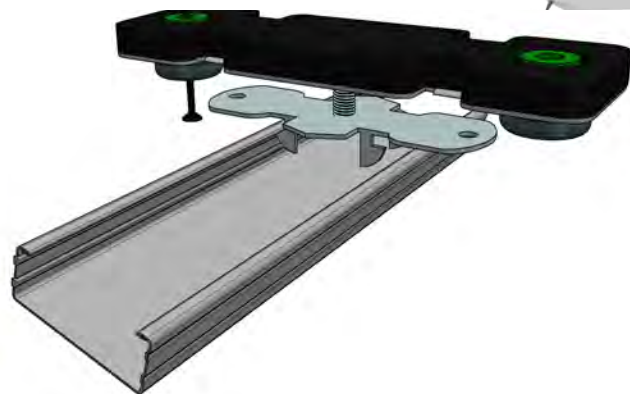
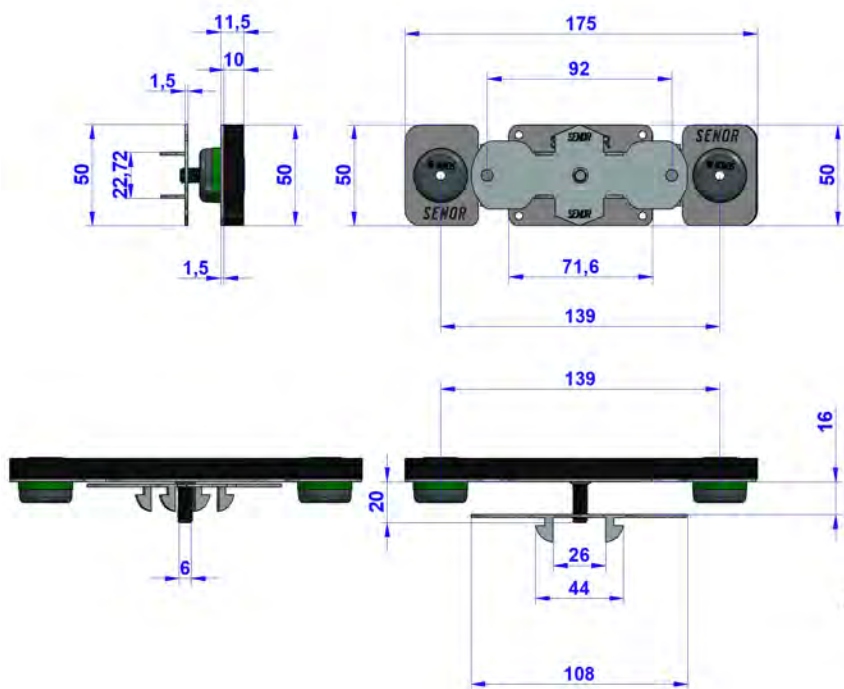

FTD NIVEL 47

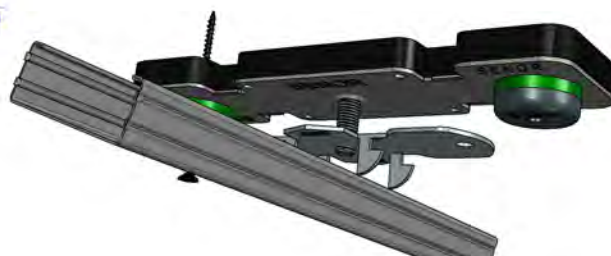



New
Patented
P.T. 201531558(6)

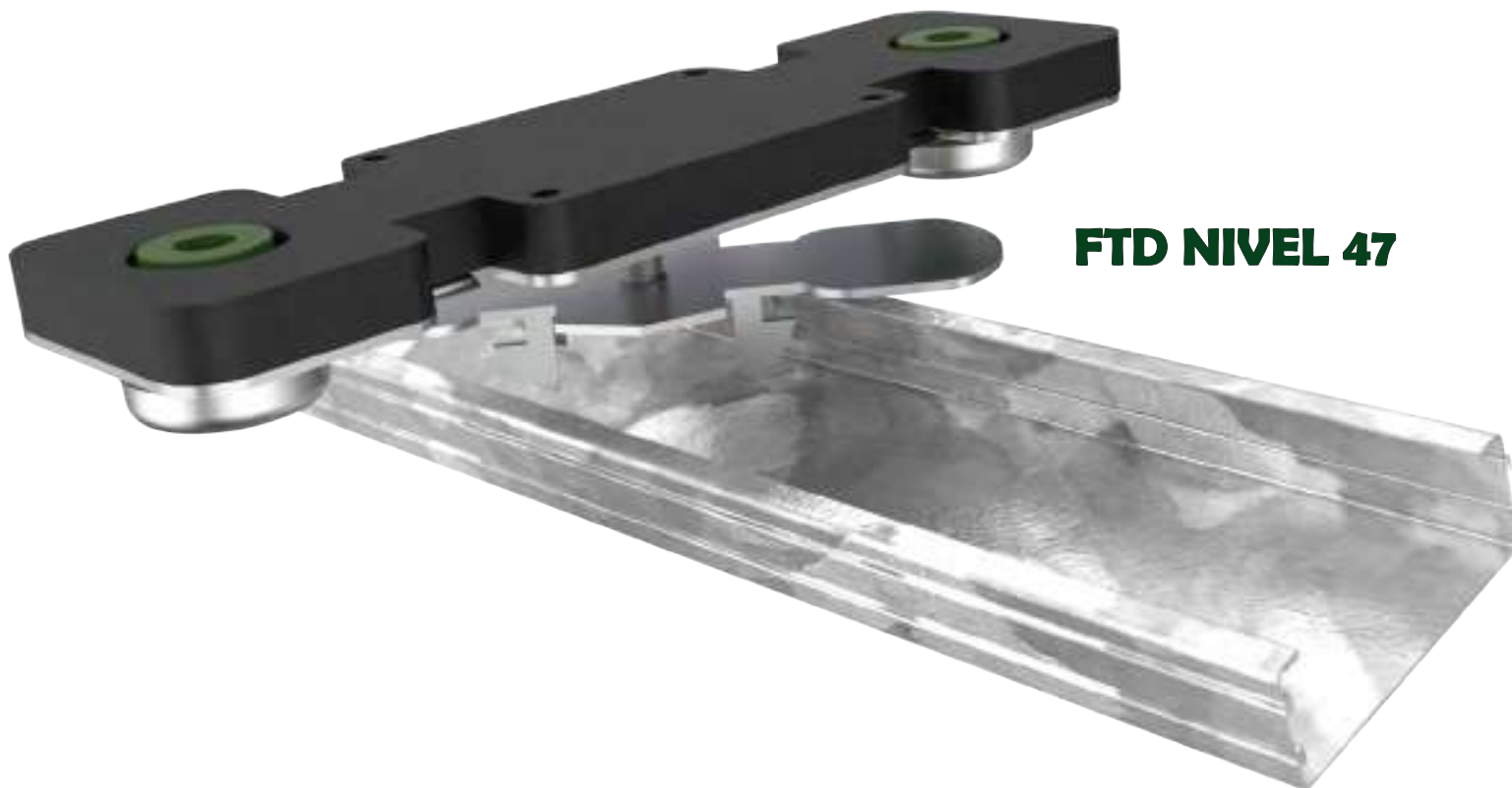

FTD NIVEL 47

A clip specially designed for
ACOUSTIC CEILING & DRY LINING

ISO 9001:2015



FTD NIVEL 47

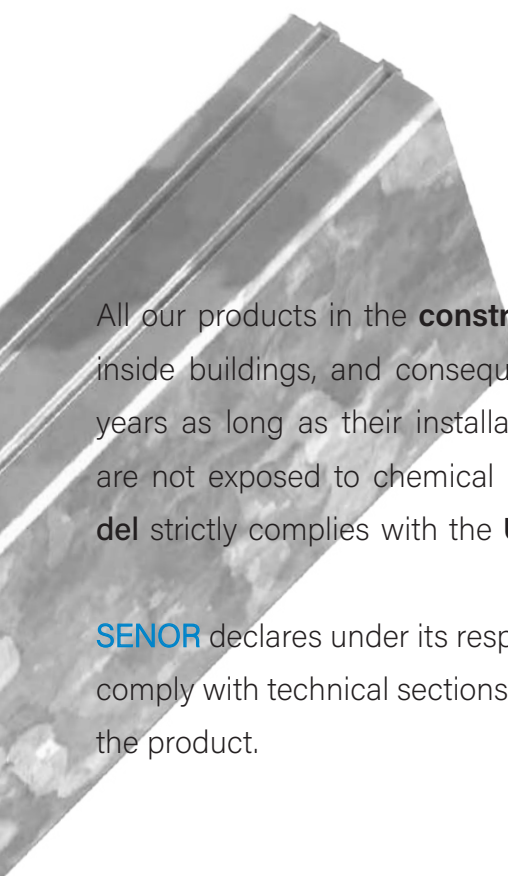

Certificate of **CONFORMITY**

SEÑOR certifies:

All our products in the **construction range** for acoustic false CEILINGs and DRY LINING SYSTEMS inside buildings, and consequently also the **FTD NIVEL 47 model**, have an optimal aging life of 10 years as long as their installation is carried out under normal **environmental conditions** and they are not exposed to chemical components that might degrade the product. The **FTD NIVEL 47 model** strictly complies with the **UNE 100-153-88 EX standard**: anti-vibration mounts: selection criteria.

SEÑOR declares under its responsibility that the following anti-vibration suspension components strictly comply with technical sections of assembly and application appearing in the technical documentation of the product.

WARNING

Important information

SEÑOR reserves for itself the right to change the technical specifications of the product without prior notice. It is a user's responsibility to know and to use the latest and updated version of the product data sheet, a copy of which will be sent to whom may request it. This information and, in particular, the recommendations relating to the application and end use of the product are given in good faith, based on current knowledge and experience of **SEÑOR** of their products, when they are correctly installed under normal circumstances and within their useful life.

PROJECT MANAGER: David Muñoz, SEÑOR

New

Patented

P.T. 201531558(6)