

4360/47 A DS MODEL

RUBBER + STEEL HANGER WITH DIRECT FASTENING TO TC45/48 METAL CHANNEL

The **4360/47 A DS** model is a **RUBBER + STEEL** hanger with locking device (**DS**) devised to provide quality to any given acoustic system and to eradicate sound frequencies and vibrations. This hanger get fastened into the channel easily and quickly thanks to our exclusive design. *We are the only ones who can manufacture it.*

The **4360/47 A DS** model is made of a high quality polymer (rubber) which provides improvements in the vibro-acoustic field. Its main use is to hang acoustic plasterboard ceilings using metal channels such as TC45/48.

The polymer of this hanger is **KRAIBURG-TP**, tested according to standard **UNE-EN ISO 10846-1:2009** (UNE: Spanish Association for Standardization). It reaches a resonance frequency of **7-15 Hz**.

**This product has been registered in the Spanish Patents and Trademarks Office.*



REF	COLOUR	METRIC MIN-MAX	CHANNEL (mm)	LOAD (Kg) MIN-MAX	PACKING
SE-4360/47 ADS/30		6 - 8	45 - 48	27 - 50	30
SE-4360/47 ADS/100		6 - 8	45 - 48	27 - 50	100

USES

Its main use is the installation of acoustic ceilings using galvanized steel channel such as **F530**, Maestra 4717, **TC-47** or similars.

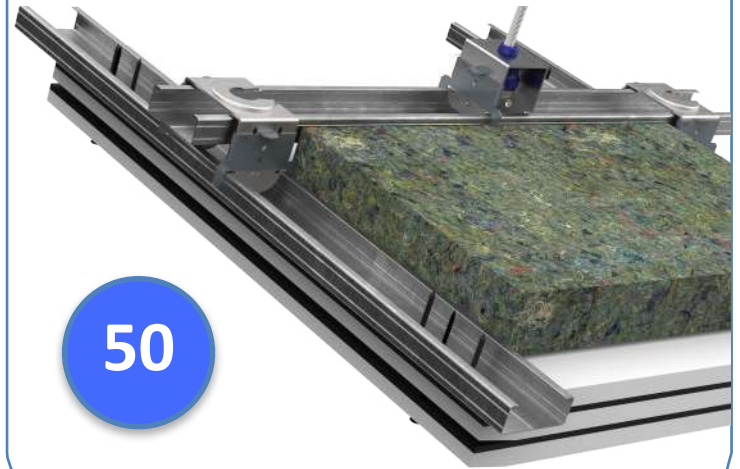

METAL CHANNEL

Galvanized steel ceiling channel of **45/48 millimeters**

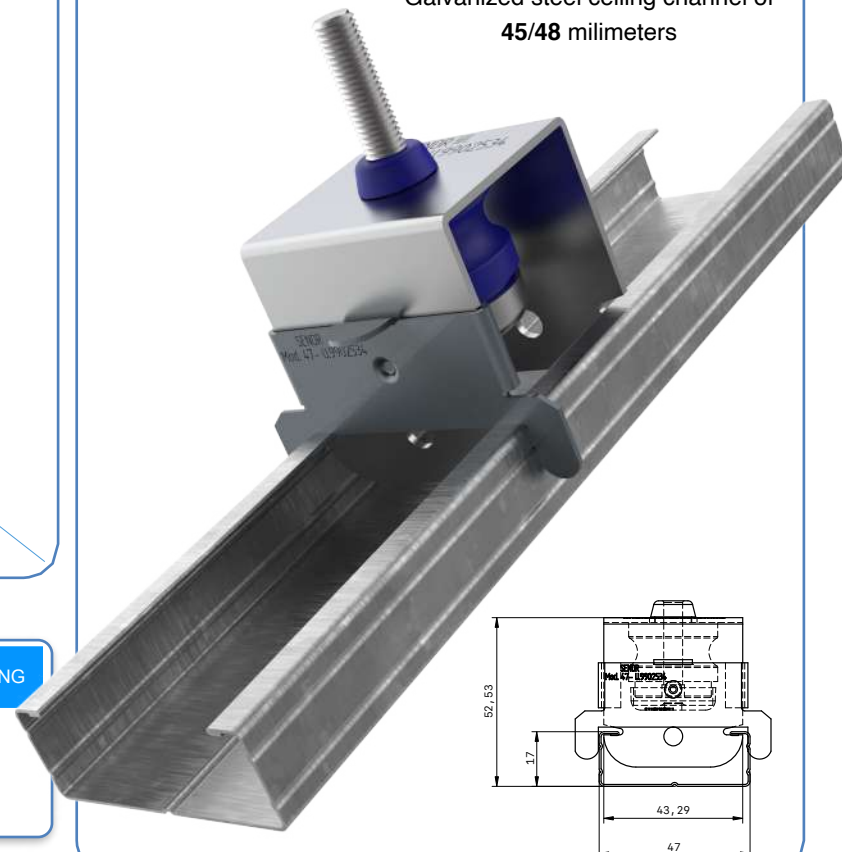

4360/47 A DS MODEL



SENR Aisladores acústicos

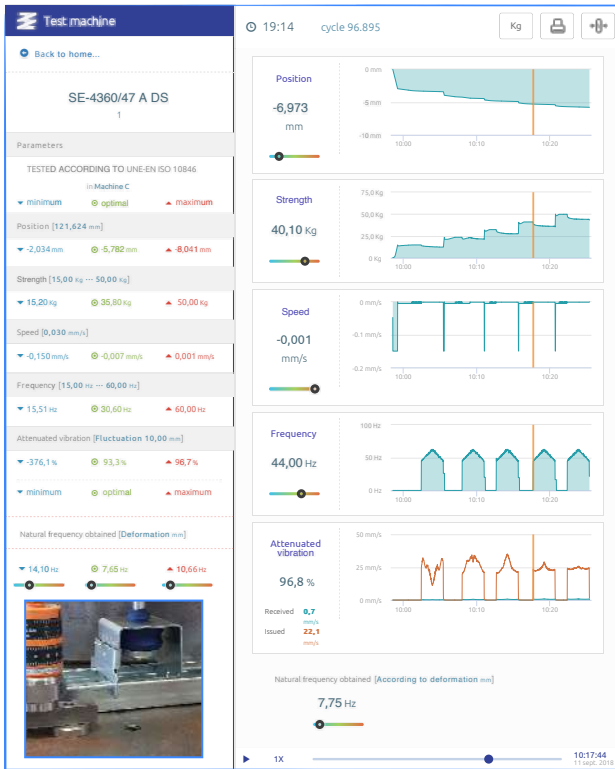
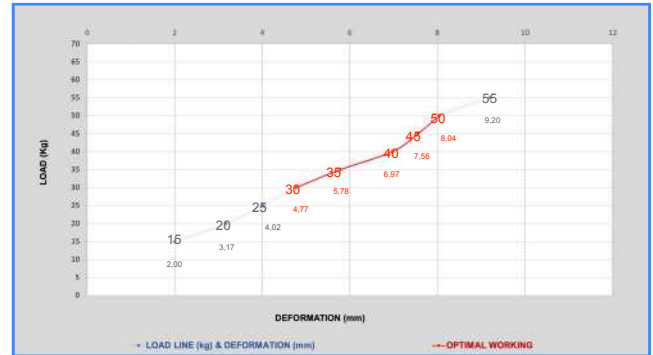
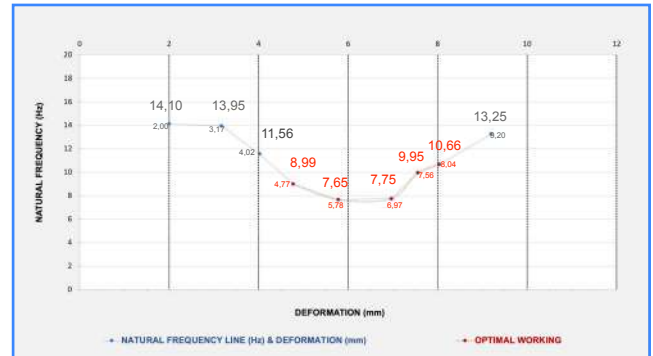

Chart 1



Laboratory test
UNE-EN ISO 10846-1:2009

Chart 2



LOAD (Kg)	DEFORMATION (mm)	RESONANCE FREQUENCY (Hz)	SWEEP (Hz)		SOUNDPROOFING LEVEL (%)	
25	4.02	11.56	25	50	72.80	94.35
30	4.77	8.99	25	50	85.15	96.66
35	5.78	7.65	25	50	89.67	97.65
40	6.97	7.75	25	50	89.37	97.54
45	7.56	9.95	25	50	81.18	95.88
50	8.04	10.66	25	50	77.78	95.24

Chart 3

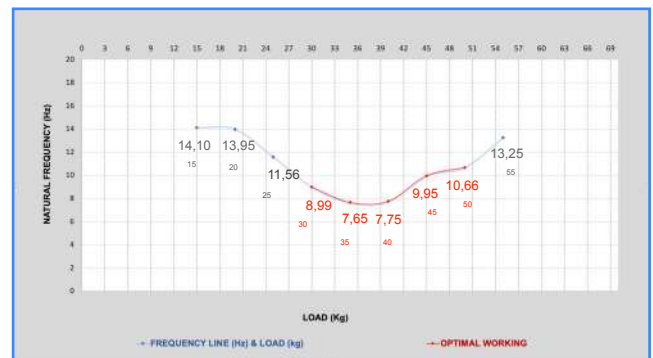



*SEÑOR Aisladores Acústicos

4360/47 A DS MODEL

3D DETAIL

Ref.SE-4360/47 A DS

BLUE RUBBER "TC-5/XNG"

MINIMUM LOAD: 27 Kg
MAXIMUM LOAD: 50 Kg

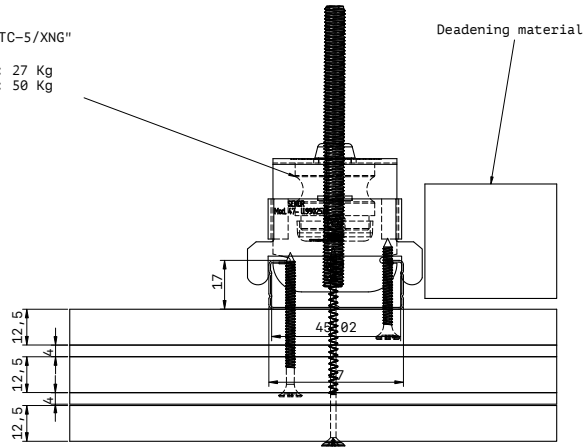

FRONT VIEW

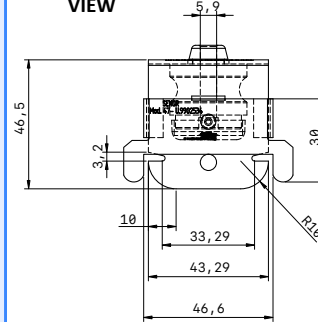

SIDE VIEW

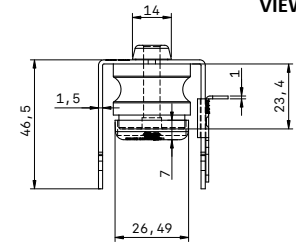

PLANT VIEW

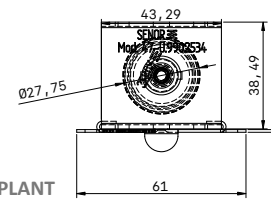

3D VIEW

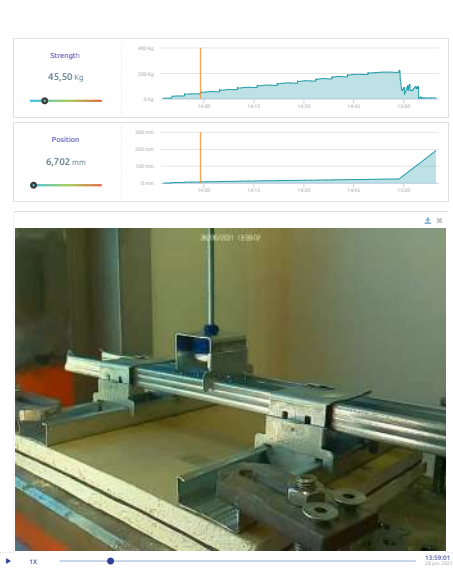
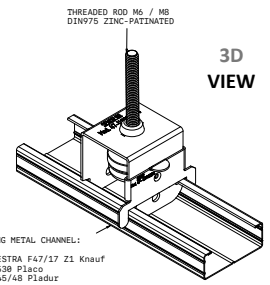

Applied load: 45,5 Kg

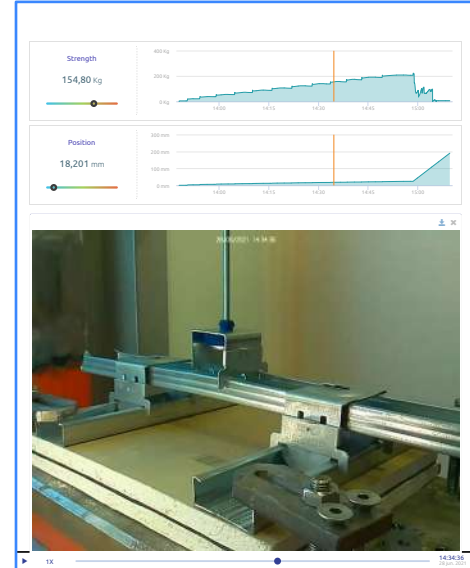

Applied load: 154,8 Kg

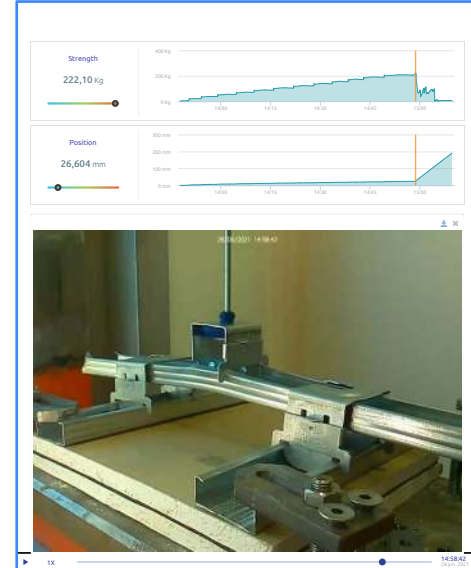

Applied load: 222,1 Kg



SEÑOR Aisladores acústicos

4360/47 A DS MODEL

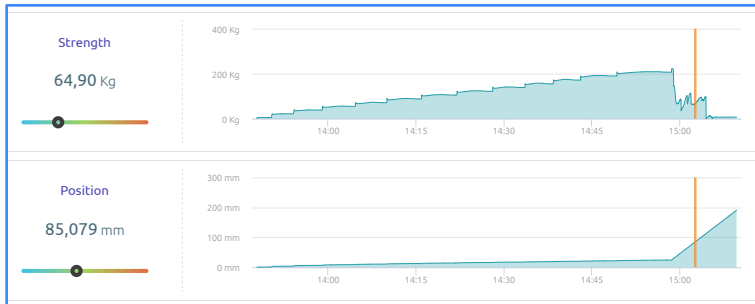

SCAN ME



Test date:
June 28, 2021 SEÑOR

Failure mode

This hanger exceeds the elastic limit of ceiling channel by reaching **222,1 kg**.

The burst test is concluded.

Conclusion

This acoustic hanger is designed to bear loads between **27-50 kg** (maximum load).

It strictly complies with standard **UNE-EN 13964:2016/A1**: Suspended ceiling. Requirements and test methods. (UNE: Spanish Association for Standardization).

INSTALLATION
Ref.SE-4360/47 A DS

