

REPORT No. B2022-LACUS-IN-175 A_En

CLIENT:	SUSPENSIONES ELÁSTICAS DEL NORTE, S.L. (SEÑOR) Polígono industrial El Garrotal, Parcela 10 - Módulos 4 y 5 14700 Palma del Río, Córdoba, España
AIM:	Laboratory measurement of improvement of airborne and impact sound insulation
STANDARDS:	EN ISO 10140-1:2021-Annex G EN ISO 10140-2:2021 EN ISO 10140-1:2021-Annex H EN ISO 10140-3:2021
TEST SPECIMEN:	LIGHTWEIGHT ACOUSTIC FLOOR WITH WOOD (SEÑOR+ChovA): - ChovACUSTIC PLUS FIELTEX (ChovA) - SE-FTD RASTREL & SE-FTD RASTREL-L dampers (SEÑOR) - ChovANAPA 4 cm PANEL 600 (ChovA) - SE-BEC-15X170 (SEÑOR) - 40x40 mm pine strip - SE-MONT-BICAPA-40 (SEÑOR) - 16 mm DM board - ViscoLAM 100 (ChovA) - 16 mm DM board

ORIGINAL REPORT ISSUE DATE: **20th September 2022**

TRANSLATION DATE: **10th October 2022**

Technical Consultant
<i>Susana Lopez de Aretxaga</i>
Susana Lopez de Aretxaga

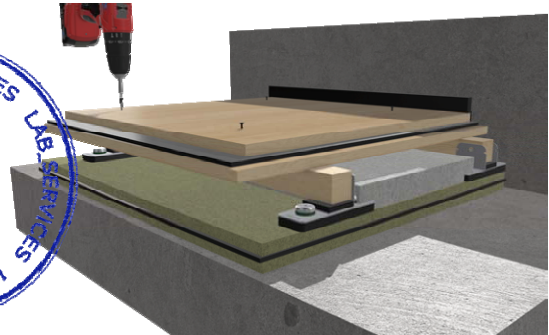
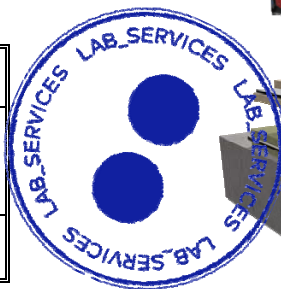

The technical ownership of the ENAC Accreditation No. 4/LE456 falls to FUNDACIÓN TECNALIA R&I, the same way as the technical signatures of this report. The test is performed by personnel of TECNALIA (Construction Lab_services Area). Facilities where the measurements are carried out belong to the Acoustics Area of the Building Quality Control Laboratory of the Basque Government, located in Agirrelanda, 10, 01013 VITORIA-GASTEIZ (Spain).

- This document is the English version of the original report issued in Spanish, B2022-LACUS-IN-175 A (20th September 2022). In case of lawsuit, the original version shall prevail.
- The results of the current report concern only and exclusively the test specimen.
- This report shall not be reproduced, except in full, without the express authorization of FUNDACIÓN TECNALIA R&I.
- Uncertainty related to the tests is available to the customer, if required.
- TECNALIA is not responsible for the information provided by the client.

1. TEST SPECIMEN DESCRIPTION

The test specimen consists of a floor covering, with the following composition according to the information provided by the applicant:

Laboratory test specimen code: B2022-175-M897

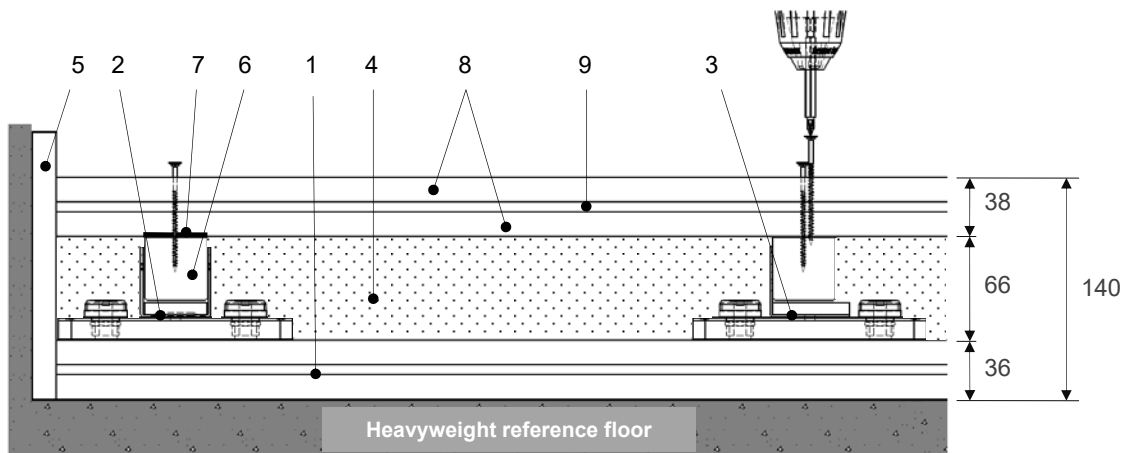

Sketch 1 – Vertical section. Nominal cotes in mm

1. ChovACUSTIC PLUS FIELTEX (ChovA): Multilayer compound composed by 2 layers of textile felt thermally adhered to a high-density viscoelastic sheet of 4 mm. 36 mm thick and 7,2 kg/m² of estimated superficial mass. 1 m wide format. Arranged on the heavyweight reference floor, with tongue-and-groove joint between sections.
2. SE-FTD RASTREL (SEÑOR): Damper composed by 2 mm high-quality galvanized steel structure + double polymer core + 12 mm BEC EPDM CR-130 strip + 1,5 mm U shaped rolled steel sheet + 10 mm BEC EPDM CR-130 strip. Arranged on Compound '1', in perimeter.
3. SE-FTD RASTREL-L (SEÑOR): Damper composed by 2 mm high-quality galvanized steel structure + double polymer core + 12 mm BEC EPDM CR-130 strip + 1,2 mm L shaped rolled steel sheet + 8 mm BEC EPDM CR-130 strip. Arranged on Compound '1', in interior area.
4. ChovANAPA 4 cm PANEL 600 (ChovA): Polyester fiber (40 mm thick and 14 kg/m³). 2 layers of panels arranged on Compound '1' and between pine strips, butt jointed each other.
5. SE-BEC-15x170 (SEÑOR): EPDM CR-130 Microcellular self-adhesive acoustic strip (15 mm thick x 170 mm wide), adhered to the perimeter.
6. 40x40 mm pine strip: Fitted and mechanically fixed to the dampers.
7. SE-MONT-BICAPA-40 (SEÑOR): Decoupling band (acts as separator between DM boards and pine strip structure to reduce the transmission of vibrations between both components). Self-adhesive, 5,5 mm thick and 4 cm wide. Composed of EPDM 2,5 mm thick + cross-linked polyethylene 3 mm thick. Adhered to pine strips on the face against DM board.
8. 16 mm DM board: DM Board 1220x2440x16 mm thick and 12,1 kg/m².
9. ViscoLAM 100 (ChovA): High density viscoelastic membrane in roll (6 mm thick and 9 kg/m²). Arranged on hidden DM board and against SE-BEC strip. 4 sections of 1 m thick, with a 6-35 cm overlap between them.

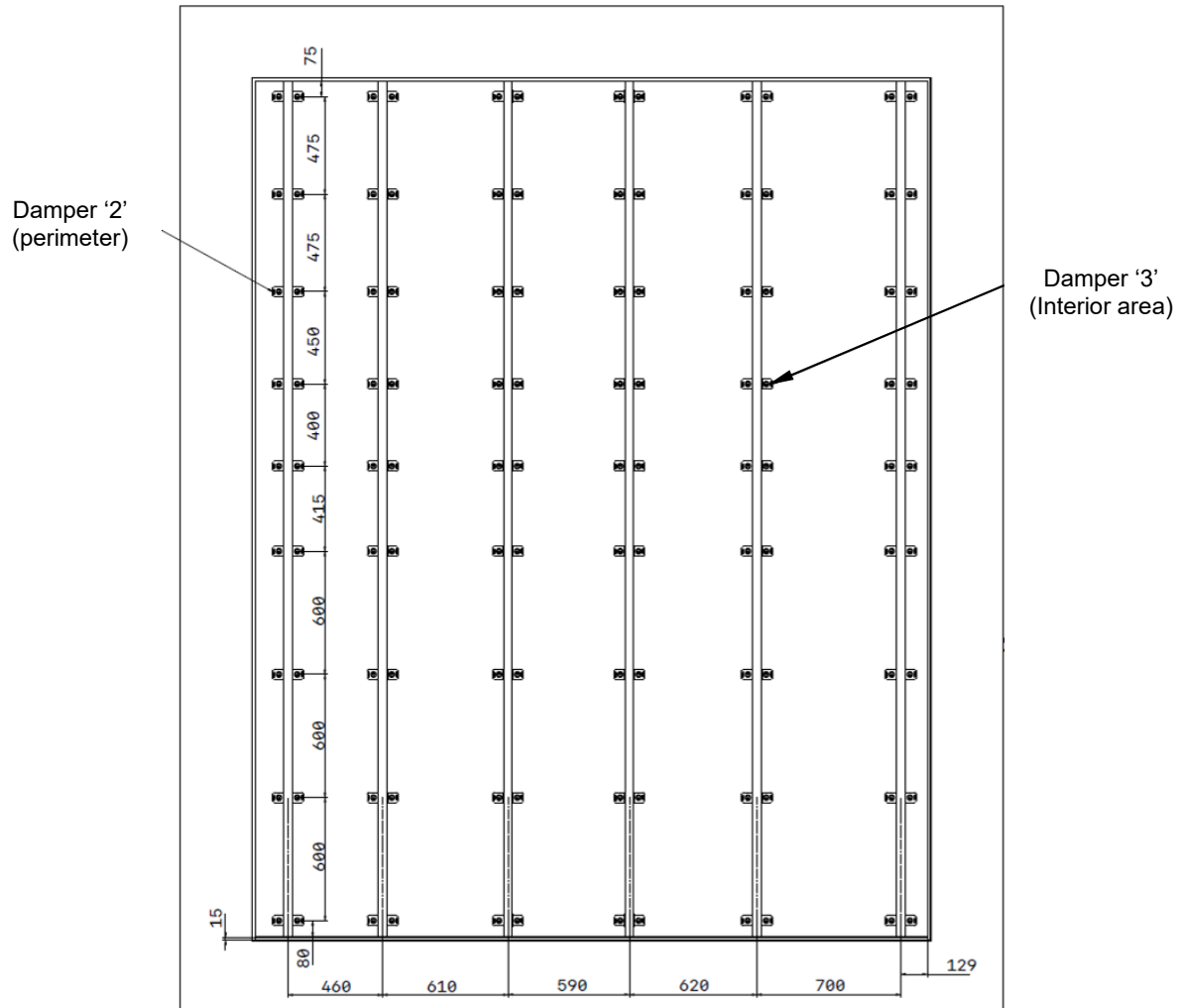
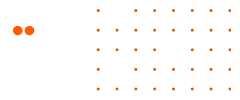

Pine strips mechanically fixed to the dampers

Sketch 2 – Arrangement of dampers. Cotes in mm



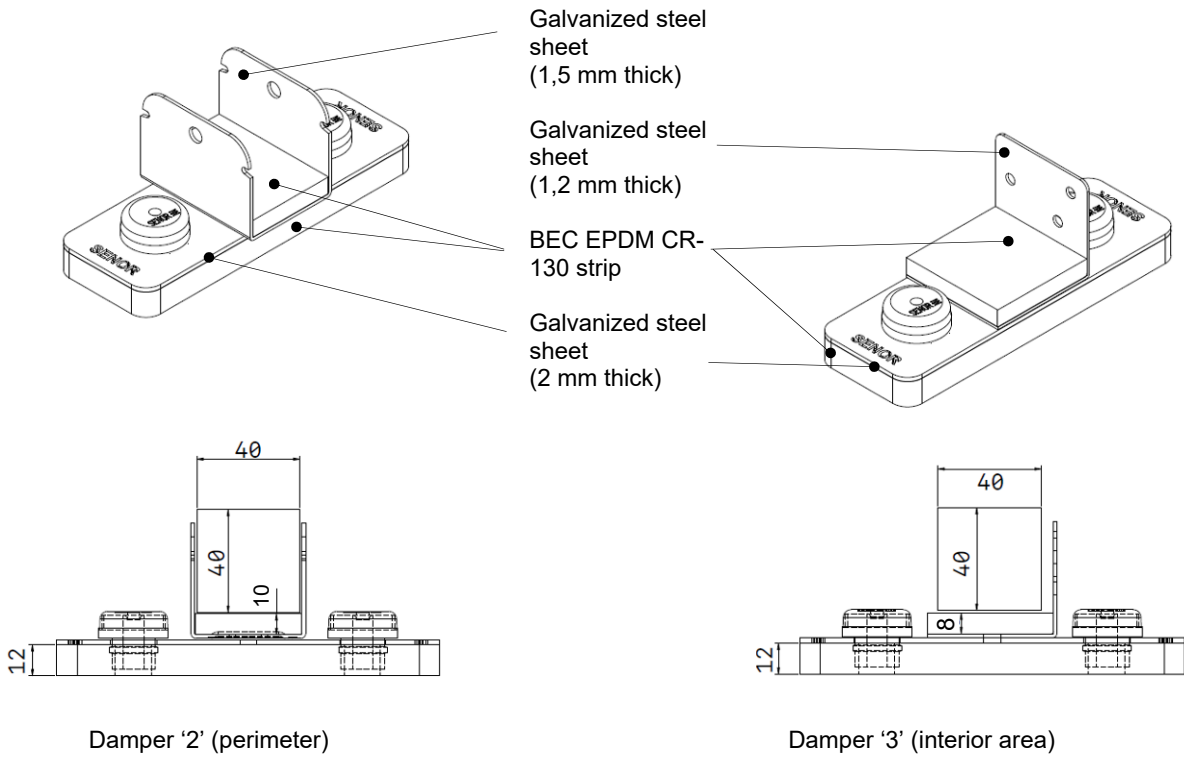
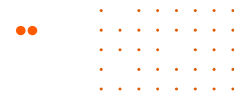

Sketch 3 – Description and photos of dampers. Cotes in mm



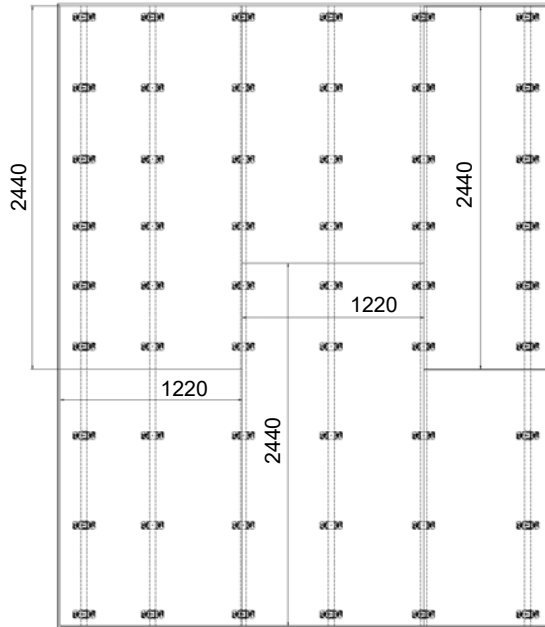

Interior layer on pine strips

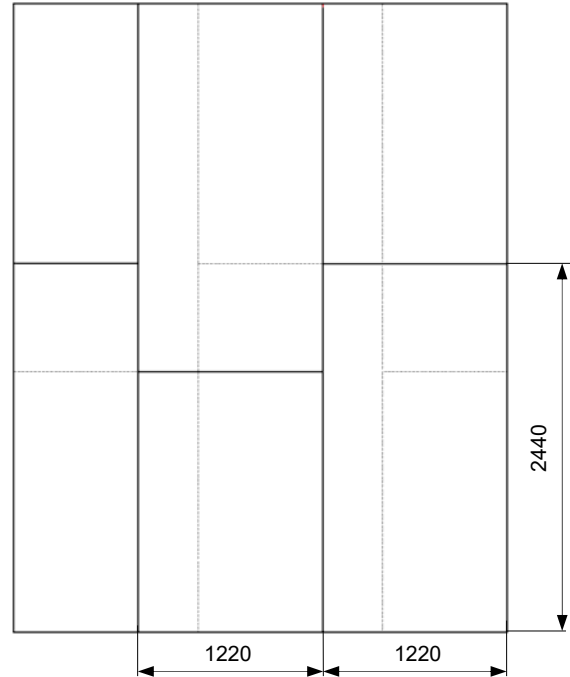

Exposed layer on interior layer

- Butt jointed boards, against SE-BEC strip and mechanically fixed to the pine strips by 35 mm screws, each ~550 mm in inner layer and each ~400 mm in exposed layer.
- Joints between boards and perimeter joint between boards and SE-BEC strip, sealed with silicone, on both layers.

Sketches 4 and 5 – DM boards arrangement. Cotes in mm



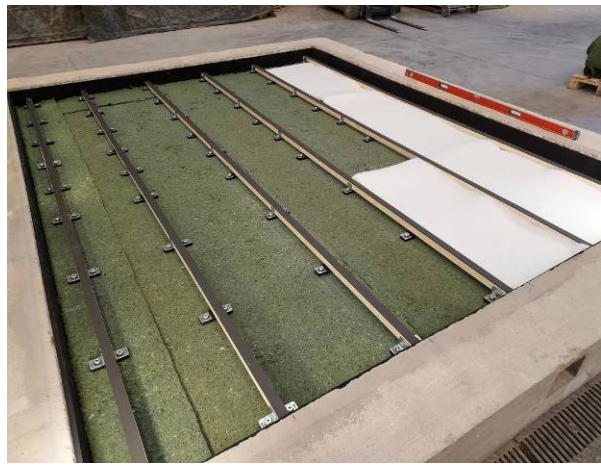

Photos of assembly of test specimen



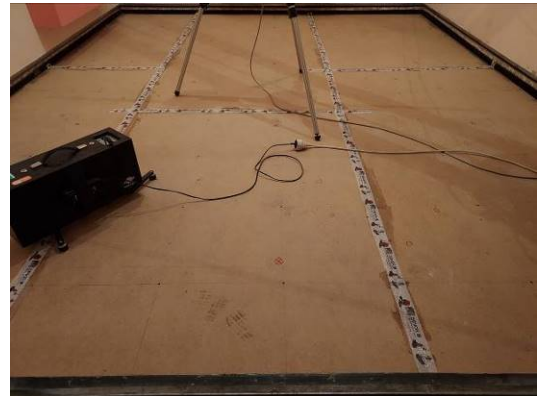
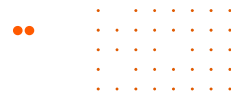

**Photos of test specimen in the acoustic rooms
Under load (left) and without loading (right)**

Test arrangement:

Test specimen placed on the heavyweight reference floor, provided by the laboratory in its final condition.

Test specimen dimensions: 4,2 x 3,3 m (surface 13,86 m²).

Floor covering Category II, according to EN ISO 10140-1:2021.

Material delivered by: SENOR, its referenced material in test specimen description and the no referenced one, and Asfaltos Chova, S.A (ChovA), its referenced material in test specimen description.

Assembly performed by: SENOR

Assembly end date: 10th May 2022

2. TEST FACILITIES

The test is performed in the vertical transmission rooms of the laboratory, composed of a source and a receiving room. The receiving room is formed by a concrete outer enclosure of 20 cm of thickness and a concrete inner enclosure of 10 cm of thickness, both acoustically disconnected. The source room, of 40 cm of thickness, is formed by a double enclosure of metal profile and gypsum board, both acoustically disconnected. The mobility of the source room allows the assembly of the test specimen outside and its later movement into the test rooms. Laboratory test facilities comply with the requirements of EN ISO 10140-5:2021.



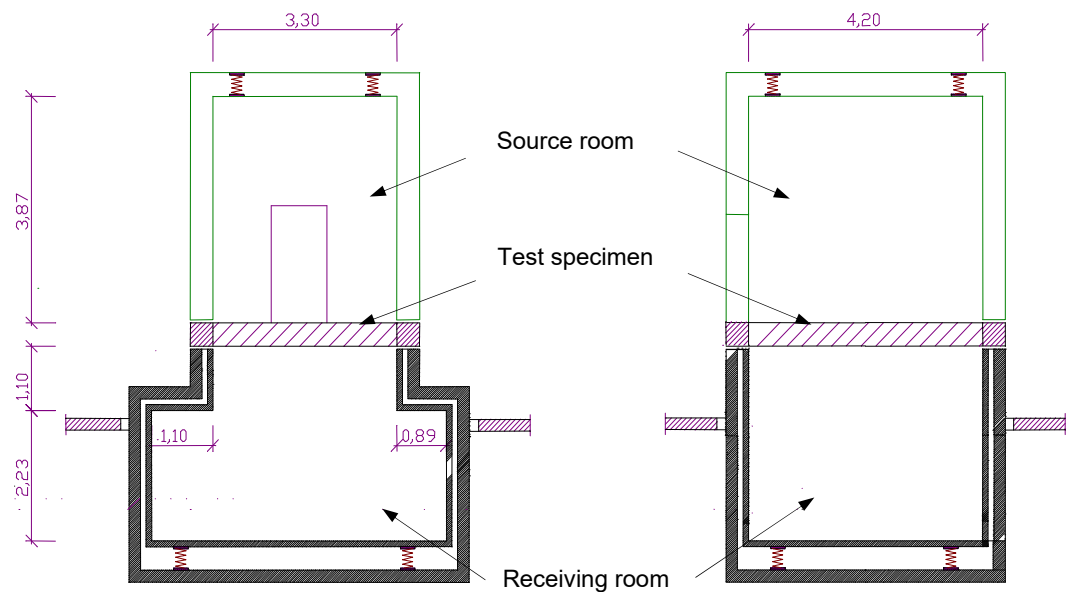

Sketch of vertical transmission acoustic rooms

3. EQUIPMENT AND TEST CONDITIONS

Equipment

Microphones	Brüel&Kjær 4943; Serie No. 3188436	Brüel&Kjær 4943; Serie No. 3188435
Preamplifiers	Brüel&Kjær 2669; Serie No. 1948764	Brüel&Kjær 2669; Serie No. 2025844
Sound sources	Brüel&Kjær 4296; Serie No. 2071420	CERWIN VEGA; No. 012446
Booms	Brüel&Kjær 3923; Serie No. 2036584	Brüel&Kjær 3923; Serie No. 2036585
Tapping machine	Brüel&Kjær 3207; Serie No. 02675448	
Analyser	Nor850-MF1; Serie No. 8501186	
Amplifier	LAB 300; 970-967	
Equalizer	Sony, SRP-E100; Serie No. 400238	
Calibrator	Brüel&Kjær 4231; Serie No. 2061476	
Atmospheric conditions meter	Rotronic BL-1D; Serie No. A19060062 Measurement uncertainty: T ($\pm 0,5$ °C), H (± 4 %), P (± 2 mbar) T: Air temperature; H: Relative humidity; P: Static pressure	
Test specimen temperature meter	TC Direct 401-215 type T s/n - 05LA0T003	



4. TEST PROCEDURE AND EVALUATION

4.1 Improvement of airborne sound insulation

The improvement of airborne sound insulation of a lining is characterized by the sound reduction improvement index (ΔR). For its determination, the measurement of airborne sound insulation is performed according to EN ISO 10140-2:2021, both for the basic element (heavyweight reference floor specified in EN ISO 10140-5:2021-Annex B) and the basic element + lining.

The sound reduction improvement index (ΔR) of a lining placed on a basic element, for the one-third octave band from 100 Hz to 5 kHz, is obtained according to standard EN ISO 10140-1:2021-Annex G, as the difference between the sound reduction indices of the basic element with and without the lining, as detailed in the equation:

$$\Delta R = R_{\text{with}} - R_{\text{without}}$$

R_{with} : Sound reduction index of the basic element with lining, from 100 to 5000 Hz

R_{without} : Sound reduction index of the basic element without lining, from 100 to 5000 Hz

The sound reduction index, R , for the one-third octave band from 100 Hz to 5 KHz is calculated according to EN ISO 10140-2:2021 using the following formula:

$$R = L_1 - L_2 + 10 \cdot \log S/A$$

L_1 : Average sound pressure level in the source room

L_2 : Average sound pressure level in the receiving room

S : Test specimen area

A : Equivalent sound absorption area in the receiving room

The measurement of the average sound pressure levels L_1 and L_2 , is performed by emitting an equalized white noise, from 100 Hz to 5 kHz, using a moving omnidirectional sound source. The sound field in the source and receiving rooms is sampled using a moving microphone with a sweep radius of 1 m and a traverse period of 16 s during 32 s of measure, for the basic element and through six fixed positions of the microphone path, for the basic element with lining. Background noise in the receiving room for the one-third-octave band from 100 Hz to 5 KHz, is measured according to the same measurement process of sound field in the receiving room.

The equivalent sound absorption area for the one-third octave band from 100 Hz to 5 kHz is evaluated from the reverberation time measured in the receiving room, using Sabine's formula:

$$A = 0,16 \cdot V/T$$

A : Equivalent sound absorption area in the receiving room

T : Reverberation time in the receiving room

V : Receiving room volume

Reverberation time in the receiving room is determined by using two positions of the sound source and three fixed microphone positions for each source position distributed at 120° in the microphone path.

Measuring chain is verified just before and after the execution of the test.





The guidelines indicated in the applicable internal procedures have been followed:

- PE.CM-AA-61-E: “Procedure for the determination of the airborne sound insulation into the horizontal and vertical transmission rooms”.
- PE.MC-AA-06-M: “Procedure to manage the test specimens for acoustic tests in laboratory”.

4.2 Improvement of impact sound insulation

The improvement of impact sound insulation of a floor covering is defined by the Reduction of impact sound pressure level (ΔL). Its determination requires the impact sound insulation test of the heavyweight reference floor specified by EN ISO 10140-5 Annex C, without and with the floor covering, according to standard EN ISO 10140-3:2021.

The test of the floor covering on the heavyweight reference floor is performed under normalized load (22 kg/m²), as specified in EN ISO 10140-1:2021-Annex H for coverings of category II. Also presented, as additional information, the results of the floor covering tested without loading.

Load composed by twelve units, equidistantly distributed on the test surface, arranged in 3 rows parallel to the length of the sample at 1100 mm between rows and 4 loads per row at 1050 mm between loads. Loading time of 1 hour.

The Reduction of impact sound pressure level, ΔL , in decibels, of the floor covering at one-third octave frequency band is obtained from the difference between normalized impact sound pressure levels of the heavyweight reference floor without and with the floor covering:

$$\Delta L = L_{n,0} - L_n$$

$L_{n,0}$: Normalized impact sound pressure level of the heavyweight reference floor without floor covering, between 100 and 5000 Hz.

L_n : Normalized impact sound pressure level of the heavyweight reference floor with floor covering, between 100 and 5000 Hz.

Both levels ($L_{n,0}$ and L_n) at each one-third octave frequency band between 100 Hz and 5 KHz, are obtained according to the following formula:

$$L_{n,0} = L_i + 10 \cdot \log A/A_0 ; L_n = L_i + 10 \cdot \log A/A_0$$

L_i : Impact sound pressure level

A : Equivalent absorption area in the receiving room

A_0 : Reference equivalent absorption area (10 m²)

When correcting by the airborne sound transmission from the source room, the levels ($L_{n,0}$ and L_n) are obtained by the following formulas:

$$L_{n,0} = 10 \lg \left(10^{L_i/10} \cdot 10^{(L_{TS}-D)/10} \right) + 10 \lg \left(\frac{A}{A_0} \right) ; L_n = 10 \lg \left(10^{L_i/10} \cdot 10^{(L_{TS}-D)/10} \right) + 10 \lg \left(\frac{A}{A_0} \right)$$

L_{TS} : Sound pressure level generated by the impact machine in the source room

D : Difference of sound pressure level: $D = R - 10 \lg(S/A)$.





The measurement of the impact sound pressure level, L_i , in a one-third-octave band in the receiving room is performed by exciting the sample using a standard tapping machine, placed at six positions randomly distributed on the test specimen. For each position, the sound field in the receiving room is sampled using a moving microphone with a sweep radius of 1 m and a traverse period of 16 s during 32 s of measure, for the heavyweight reference floor and through six fixed positions of the microphone path, for the floor with floor covering. The impact sound pressure level for the test specimen is obtained as the average of the measured impact sound pressure levels. To determinate L_n and L_{n0} , the same positions of the standard tapping machine are used. The standard tapping machine has five metallic hammers of 30 mm of nominal diameter and meets the specifications of EN ISO 10140-5:2021, Annex E.

The background noise is measured in the receiving room in the one-third-octave band 100 Hz to 5 kHz, according to the same measurement process of sound field in the receiving room.

The equivalent sound absorption area between 100 Hz and 5 kHz is evaluated from the reverberation time measured in the receiving room, using Sabine's formula:

$$A=0,16*V/T$$

A: Equivalent sound absorption area in the receiving room

T: Reverberation time in the receiving room

V: Receiving room volume

The reverberation time in the receiving room is determined using two positions of the sound source and three fixed microphone positions for each source position, at 120° in the microphone path.

Measuring chain is verified just before and after the execution of the test.

The guidelines indicated in the applicable internal procedures have been followed:

- PE.CM-AA-62-E: "Procedure to determinate the impact sound insulation and the reduction of impact level in the vertical transmission room".
- PE.MC-AA-06-M: "Procedure to manage the test specimens for acoustic tests in laboratory".

5. RESULTS

5.1 Improvement of airborne sound insulation

The following results are presented:

- Sound reduction improvement index, ΔR , in decibels, for the one-third-octave band from 100 Hz to 5000 Hz, in table and graph.
- Weighted sound reduction improvement index, $\Delta R_{w,heavy}$, calculated according to EN ISO 717-1:2020, on the heavyweight reference floor.

$$\Delta R_{w,heavy} = R_{w,ref,with} - R_{w,ref,without}$$

$$R_{ref,with} = R_{ref,without} + \Delta R$$

$R_{ref,without}$ given in EN ISO 717-1:2020, Annex E



- A-weighted improvement of sound reduction indices $\Delta(R_w+C)_{\text{heavy}}$ and $\Delta(R_w+C_{\text{tr}})_{\text{heavy}}$, calculated in an equivalent way.
- A-weighted improvement of sound reduction indices from 100 to 5000 Hz, $\Delta R_A = \Delta(R_w+C_{100-5000})_{\text{heavy}}$ and $\Delta R_{A,\text{tr}} = \Delta(R_w+C_{\text{tr},100-5000})_{\text{heavy}}$, calculated in an equivalent way.

Additionally, are presented:

- Sound reduction index of the heavyweight reference floor with lining, R_{with} , for the one-third-octave band from 100 Hz to 5000 Hz.
- Sound reduction index of the heavyweight reference floor without lining, R_{without} , for the one-third-octave band from 100 Hz to 5000 Hz.
- Global indices $R_w(C; C_{\text{tr}})$, R_A and $R_{A,\text{tr}}$ for both elements mentioned above, calculated as follows:
 - R_w : Weighted sound reduction index, calculated according to EN ISO 717-1:2020, from the sound reduction index, R .
 - C and C_{tr} : Spectrum adaptation terms from 100 to 3150 Hz, calculated according to EN ISO 717-1:2020, which are the values, expressed in decibels, to be added to the global magnitude value R_w to consider the characteristics of the pink noise spectrum (C) and traffic noise spectrum (C_{tr}), respectively.
 - R_A and $R_{A,\text{tr}}$: Global indices calculated according to the expression of *Documento Básico "DB-HR Protección frente al ruido" - Código Técnico de la Edificación (CTE)*, from the sound reduction index, R , obtained by laboratory measurement:
 - R_A : A-weighted sound reduction index, from 100 to 5000 Hz, expressed to one decimal place.
 - $R_{A,\text{tr}}$: A-weighted sound reduction index for exterior traffic noise, from 100 to 5000 Hz, expressed to one decimal place.

The R value marked with * means that is greater than or equal to the indicated value, due to the approximation in less than 15 dB for the R'_{max} of the test facilities. The ΔR value marked with * means that is greater than or equal to the indicated value, due to the measurement limit of the R value marked with * on the corresponding frequency. The global index marked with ** means that is greater than or equal to indicated value, due to the limit values in frequencies marked with *.

F(Hz)	100	125	160	200	250	315	400	500	630
R'_{max} (dB)	61,2	63,7	72,6	67,6	76,3	79,5	84,9	89,2	93,4
F(Hz)	800	1000	1250	1600	2000	2500	3150	4000	5000
R'_{max} (dB)	95,3	97,4	97,7	99,0	99,6	96,4	92,3	84,8	81,5

5.2 Improvement of impact sound insulation

The following results are presented for the test specimen:

- The reduction of impact sound pressure level (ΔL) at one-third octave frequency band between 100 and 5000 Hz, in table and graph.

- The weighted reduction of impact sound pressure level (ΔL_w) of the floor covering, according to EN ISO 717-2:2020, obtained using the following formula:

$$\Delta L_w = L_{n,r,0,w} - L_{n,r,w} = 78 \text{ dB} - L_{n,r,w}$$

$L_{n,r,0,w}$: Weighted normalized impact sound pressure level calculated from $L_{n,r,0}$

$L_{n,r,w}$: Weighted normalized impact sound pressure level calculated from $L_{n,r}$

$L_{n,r,0}$: Normalized impact sound pressure level of a reference floor defined in the standard EN ISO 717-2:2020

$L_{n,r}$: Normalized impact sound pressure level calculated by $L_{n,r} = L_{n,r,0} - \Delta L$.

- The spectrum adaptation term ($C_{i,\Delta}$), according to EN ISO 717-2:2020, obtained using the following formula:

$$C_{i,\Delta} = C_{i,r,0} - C_{i,r} = -11 \text{ dB} - C_{i,r}$$

$C_{i,r,0}$: Spectrum adaptation term calculated from $L_{n,r,0}$

$C_{i,r}$: Spectrum adaptation term calculated from $L_{n,r}$

Additionally, the following information is presented:

- Normalized impact sound pressure level of the floor covering on the heavyweight reference floor (L_n) between 100 and 5000 Hz.
- Normalized Impact sound pressure level of the heavyweight reference floor ($L_{n,0}$) between 100 and 5000 Hz.
- Single-number quantities ($L_{n,w}$ and $L_{n,0,w}$) of the heavyweight reference floor with and without the floor covering and Single-number quantity ($L_{n,r,w}$) and spectrum adaptation term ($C_{i,r}$).

The L_n value marked with * means that is less than or equal to the indicated value, due to the approximation of receiving level for the background noise in less than 6 dB (1,3 dB has been made for background correction). The ΔL value marked with * means that is greater than or equal to the indicated value, due to the measurement limit of the L_n value marked with * in the corresponding frequency.

**Sound reduction improvement index of a lining on heavyweight reference floor
according to EN ISO 10140-1:2021-Annex G
Laboratory measurements according to EN ISO 10140-2:2021**

CLIENT: SUSPENSIONES ELÁSTICAS DEL NORTE, S.L. (SENOR)

TEST DATE: 19th May 2022

RESULT No.: B2022-175-M897 MRA

TEST SPECIMEN: **LIGHTWEIGHT ACOUSTIC FLOOR WITH WOOD (SENOR+ChovA):**

- ChovACUSTIC PLUS FIELTEX (ChovA)
- SE-FTD RASTREL & SE-FTD RASTREL-L dampers (SENOR)
- ChovANAPA 4 cm PANEL 600 (ChovA)
- SE-BEC-15x170 acoustic strip (SENOR)
- 40x40 mm pine strip
- SE-MONT-BICAPA-40 (SENOR)
- 16 mm DM board
- ViscoLAM 100 (ChovA)
- 16 mm DM board

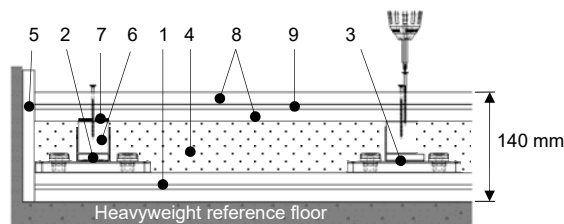

1. ChovACUSTIC PLUS FIELTEX
2. SE-FTD RASTREL damper
3. SE-FTD RASTREL-L damper
4. ChovANAPA 4 cm PANEL 600
5. SE-BEC-15x170 strip
6. 40x40 mm pine strip
7. SE-MONT-BICAPA-40
8. 16 mm DM board
9. ViscoLAM 100

Test specimen estimated superficial mass: 42 kg/m²

Test specimen area, S: 13,86 m² (3,3x4,2 m)

Heavyweight reference floor: Reinforced concrete slab of 150 mm (375 kg/m²), tested on 7th February 2022 ($R_{without}$).

V_{src} : 54,4 m³; T_{src} : 20,3 °C; H_{src} : 60 %; P_{src} : 962 mbar

V_{rec} : 64,7 m³; T_{rec} : 19,3 °C; H_{rec} : 68 %; P_{rec} : 963 mbar

V: volume; src: source room; rec: receiving room

f (Hz)	R_{with} (dB)	$R_{without}$ (dB)	ΔR (dB)
100	54,8*	37,5	17,3*
125	55,6*	44,1	11,5*
160	57,0	40,4	16,6
200	63,3*	44,6	18,7*
250	65,6*	46,8	18,8*
315	65,9*	48,6	17,3*
400	69,2	52,6	16,6
500	70,7	55,5	15,2
630	71,7	57,4	14,3
800	72,2	58,5	13,7
1000	71,6	60,4	11,2
1250	70,5	62,1	8,4
1600	72,5	64,3	8,2
2000	75,7	66,8	8,9
2500	79,5	70,0	9,5
3150	84,2*	73,6	10,6*
4000	87,3*	75,4*	11,9*
5000	88,7*	77,6*	11,1*

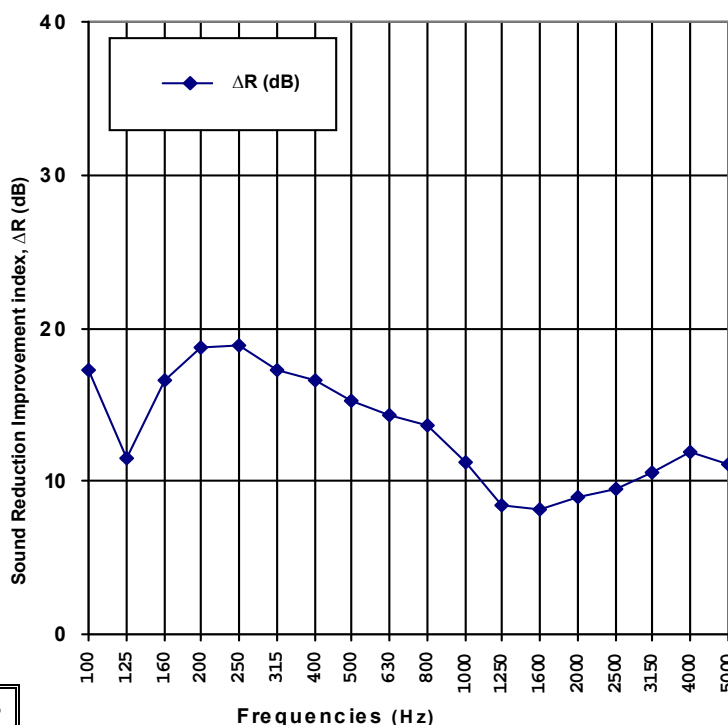

$R_{w(C); C_{tr}}_{with}$: 72(-1;-5) dB **	$R_{w(C); C_{tr}}_{without}$: 58(-2;-6) dB
$R_{A,with}$: 71,9 dBA **	$R_{A,without}$: 57,2 dBA
$R_{A,tr,with}$: 67,5 dBA **	$R_{A,tr,without}$: 51,7 dBA

Rating according to EN ISO 717-1:2020:

ΔR_{heavy} : 14 dB ** / $\Delta(R_w+C)_{heavy}$: 14 dB ** / $\Delta(R_w+C_{tr})_{heavy}$: 16 dB **

$\Delta R_A = \Delta(R_w+C_{100-5000})_{heavy}$: 14 dB ** / $\Delta R_{A,tr} = \Delta(R_w+C_{tr,100-5000})_{heavy}$: 16 dB **

* R' and $\Delta R \geq$ indicated value (measurement limit by approx. R'_{max}). ** Global index \geq indicated value.

Evaluation based on laboratory measurements obtained by an engineering method.



**Reduction of Impact Sound Pressure Level of a lining on heavyweight reference floor according to EN ISO 10140-1:2021-Annex H
Laboratory measurements according to EN ISO 10140-3:2021**

CLIENT: **SUSPENSIONES ELÁSTICAS DEL NORTE, S.L. (SENOR)**

TEST DATE: 20th May 2022

RESULT No: B2022-175-M897 MRI-CC

TEST SPECIMEN: **LIGHTWEIGHT ACOUSTIC FLOOR WITH WOOD (SENOR+ChovA):**

- ChovACUSTIC PLUS FIELTEX (ChovA)
- SE-FTD RASTREL & SE-FTD RASTREL-L dampers (SENOR)
- ChovANAPA 4 cm PANEL 600 (ChovA)
- SE-BEC-15x170 acoustic strip (SENOR)
- 40x40 mm pine strip
- SE-MONT-BICAPA-40 (SENOR)
- 16 mm DM board
- ViscoLAM 100 (ChovA)
- 16 mm DM board

Test specimen estimated superficial mass: 42 kg/m²

Test specimen area, S: 13,86 m² (3,3x4,2 m)

Test specimen tested under load.

Heavyweight reference floor: Reinforced concrete slab of 150 mm (375 kg/m²), tested on 7th February 2022 (L_{n,0}).

V_{src}: 54,4 m³; T_{src}: 21,0 °C; H_{src}: 59 %; P_{src}: 963 mbar

V_{rec}: 64,7 m³; T_{rec}: 20,5 °C; H_{rec}: 68 %; P_{rec}: 964 mbar

T_{upper floor surface centre}: 21,7 °C

V: volume; src: source room; rec: receiving room

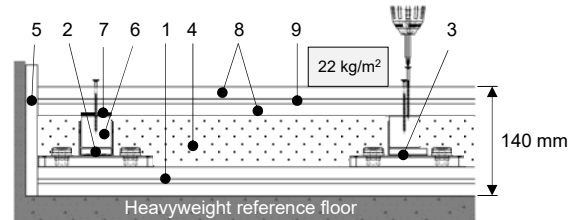

1. ChovACUSTIC PLUS FIELTEX
2. SE-FTD RASTREL damper
3. SE-FTD RASTREL-L damper
4. ChovANAPA 4 cm PANEL 600
5. SE-BEC-15x170 strip
6. 40x40 mm pine strip
7. SE-MONT-BICAPA-40
8. 16 mm DM board
9. ViscoLAM 100

f (Hz)	L _{n,0} (dB)	L _n (dB)	ΔL (dB)
100	69,6	58,0	11,6
125	62,6	53,4	9,2
160	68,9	58,3	10,6
200	68,4	57,0	11,4
250	66,6	52,9	13,7
315	68,4	50,2	18,2
400	67,8	45,3	22,5
500	68,0	40,9	27,1
630	69,2	38,3	30,9
800	70,3	34,3	36,0
1000	71,2	31,1	40,1
1250	71,9	28,1	43,8
1600	72,0	19,6	52,4
2000	71,8	11,9	59,9
2500	71,2	8,3	62,9
3150	70,9	5,4*	65,5*
4000	70,7	4,8*	65,9*
5000	69,9	5,3*	64,6*

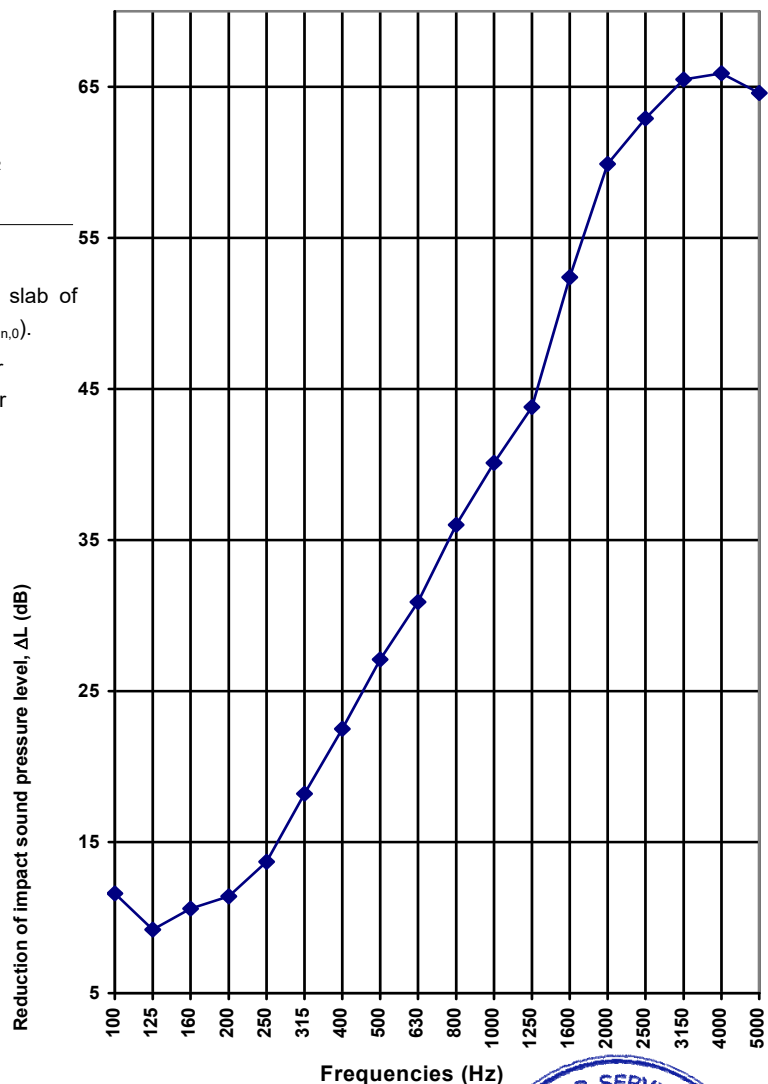

Rating according to EN ISO 717-2:2020:

ΔL_w (C_{l,Δ}): **29 (-11) dB**

L_{n,0,w}: 78 dB; L_{n,w}: 48 dB; L_{n,r,w}: 49 dB; C_{l,r}: 0 dB

* L_n ≤ indicated value (measurement limit by approx. background noise). ΔL ≥ indicated value.
L_n 1600, 2000 and 2500 Hz corrected by airborne sound transmission.

These results are based on test made with an artificial source under laboratory conditions (engineering method).



Reduction of Impact Sound Pressure Level of a lining on heavyweight reference floor according to EN ISO 10140-1:2021-Annex H
Laboratory measurements according to EN ISO 10140-3:2021

CLIENT: SUSPENSIONES ELÁSTICAS DEL NORTE, S.L. (SENOR)

TEST DATE: 19th May 2022

RESULT No: B2022-175-M897 MRI

TEST SPECIMEN: LIGHTWEIGHT ACOUSTIC FLOOR WITH WOOD (SENOR+ChovA):

- ChovACUSTIC PLUS FIELTEX (ChovA)
- SE-FTD RASTREL & SE-FTD RASTREL-L dampers (SENOR)
- ChovANAPA 4 cm PANEL 600 (ChovA)
- SE-BEC-15x170 acoustic strip (SENOR)
- 40x40 mm pine strip
- SE-MONT-BICAPA-40 (SENOR)
- 16 mm DM board
- ViscoLAM 100 (ChovA)
- 16 mm DM board

Test specimen estimated superficial mass: 42 kg/m²

Test specimen area, S: 13,86 m² (3,3x4,2 m)

Heavyweight reference floor: Reinforced concrete slab of 150 mm (375 kg/m²), tested on 7th February 2022 (L_{n,0}).

V_{src}: 54,4 m³; T_{src}: 20,3 °C; H_{src}: 60 %; P_{src}: 962 mbar

V_{rec}: 64,7 m³; T_{rec}: 19,3 °C; H_{rec}: 68 %; P_{rec}: 963 mbar

T_{upper floor surface centre}: 21,6 °C

V: volume; src: source room; rec: receiving room

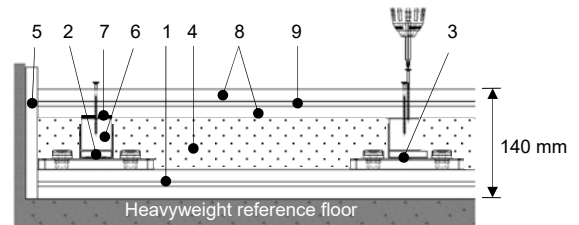

1. ChovACUSTIC PLUS FIELTEX
2. SE-FTD RASTREL damper
3. SE-FTD RASTREL-L damper
4. ChovANAPA 4 cm PANEL 600
5. SE-BEC-15x170 strip
6. 40x40 mm pine strip
7. SE-MONT-BICAPA-40
8. 16 mm DM board
9. ViscoLAM 100

f (Hz)	L _{n,0} (dB)	L _n (dB)	ΔL (dB)
100	69,6	60,3	9,3
125	62,6	55,1	7,5
160	68,9	58,8	10,1
200	68,4	56,7	11,7
250	66,6	53,2	13,4
315	68,4	50,2	18,2
400	67,8	45,3	22,5
500	68,0	41,5	26,5
630	69,2	38,8	30,4
800	70,3	34,7	35,6
1000	71,2	31,5	39,7
1250	71,9	28,3	43,6
1600	72,0	20,2	51,8
2000	71,8	12,3	59,5
2500	71,2	8,6	62,6
3150	70,9	5,8*	65,1*
4000	70,7	4,9*	65,8*
5000	69,9	5,3*	64,6*

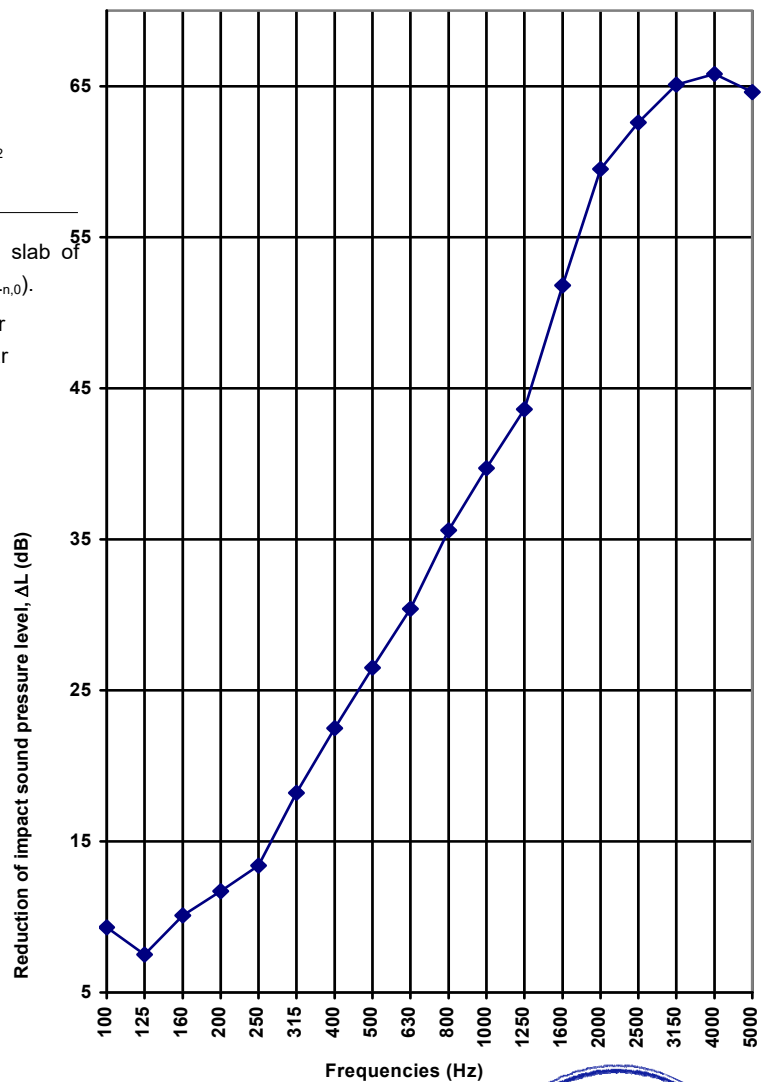

Rating according to EN ISO 717-2:2020:

ΔL_w (C_{L,Δ}): 28 (-11) dB

L_{n,0,w}: 78 dB; L_{n,w}: 49 dB; L_{n,r,w}: 50 dB; C_{L,r}: 0 dB

* L_n ≤ indicated value (measurement limit by approx. background noise). ΔL ≥ indicated value.
L_n 1600, 2000 and 2500 Hz corrected by airborne sound transmission.

These results are based on test made with an artificial source under laboratory conditions (engineering method).

