

## TS-80 V 150

### RUBBER MOUNT WITH RESTRAINT SYSTEM FOR ACOUSTIC FLOORS OR INERTIA BASES

This model is a **RUBBER** wall mount for acoustic floors devised to provide quality to any given acoustic system and to eradicate sound frequencies and vibrations.

The **SE-TS-80 V 150** includes a **PATENTED** restraint system (two protrusions in its base) which limits the movement making sure the grip to the floor. It is designed in the shape of trapezium with **X** shaped base improving the elasticity of the system and proving an excellent performance in the soundproofing field.

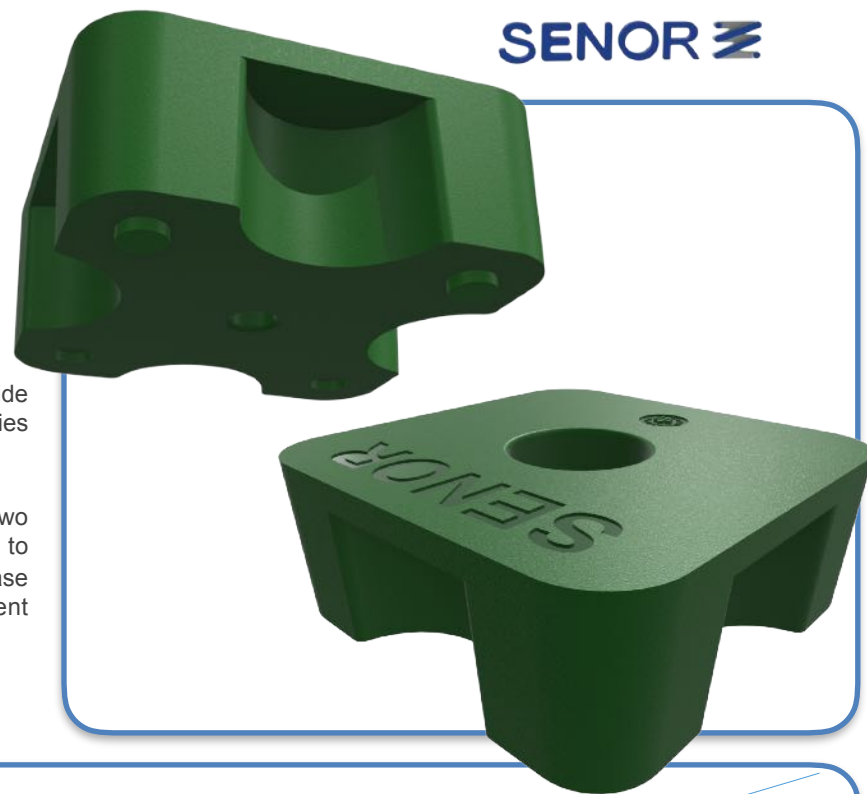

## TS-80 V 150

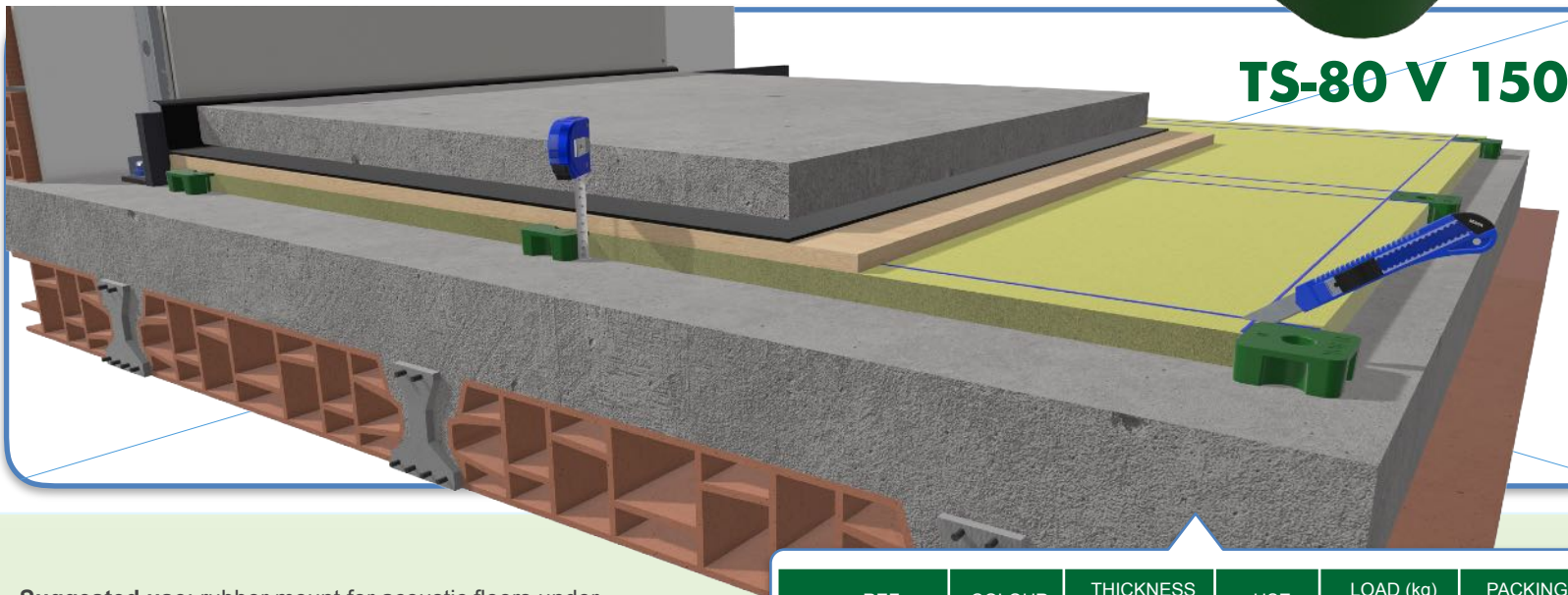

**Suggested use:** rubber mount for acoustic floors under **concrete slab**. This type of polymer has a better damping result than other rubbers such as polyurethane, polystyrene, EPDM, among others.

REF.	COLOUR	THICKNESS (mm)	USE	LOAD (kg) MIN-MAX	PACKING (Units)
SE-TS-80 V 150		30	Acoustic floors	35 - 200	16 - 50



**I+D+i**

\*This product has been registered in the Spanish Patents and Trademarks Office

#### Quality of the polymer

- Polymer: **KRAIBURG-TPE - TC4/GPN** (tested according to the Standard **UNE-EN ISO 10846-1:2009**).

- ✓ Resonance frequency: **7-15 Hz**.
- ✓ Recommended load range: **35 kg - 200 kg**.

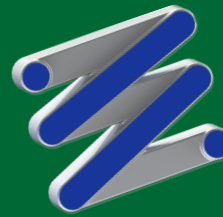

### Predicción de Impacto Sonoro (v8.0.1)

Derechos de autor del programa Marshall Day Acoustics 2014

- Key No. 6719

Margen de error de Predicción de Impacto Sonoro está generalmente entre  $L_{n,w} \pm 5$  dB



frecuencia (Hz)	Ln(dB)	Ln(dB)
50	40	
63	39	44
80	38	
100	36	
125	35	40
160	35	
200	35	
250	37	41
315	37	
400	34	
500	32	37
630	30	
800	27	
1000	24	30
1250	22	
1600	19	
2000	15	21
2500	12	
3150	8	
4000	5	11
5000	2	

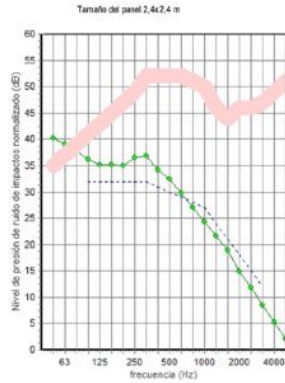

### Laboratory test UNE-EN ISO 10846-1:2009

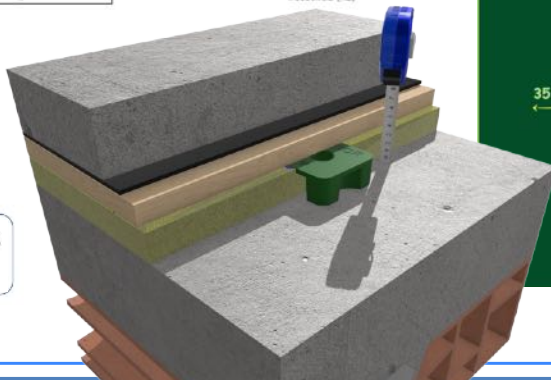
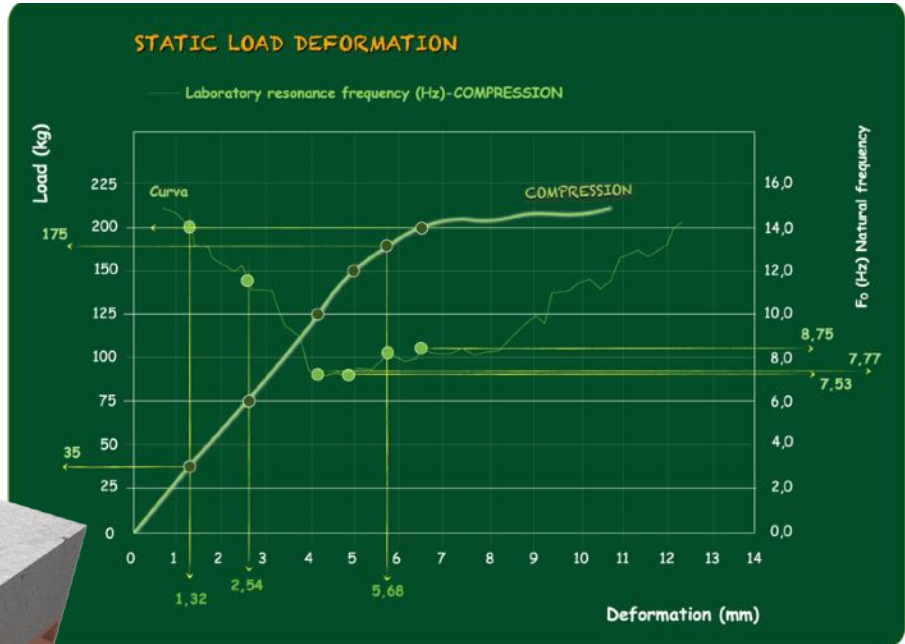

$L_{n,w}$  30 dB  
 $C_1$  0 dB

### Axial compression results

LOAD (Kg)	DEFORMATION (mm)	RESONANCE FREQUENCY (Hz)	SWEEP (Hz)		SOUNDPROOFING LEVEL (%)	
35	1,32	14,00	25	50	54,31	91,49
75	2,54	11,85	25	50	71,02	94,05
125	4,13	7,77	25	50	89,31	97,53
150	4,93	7,53	25	50	90,02	97,68
175	5,68	8,25	25	50	87,78	97,20
200	6,47	8,75	25	50	86,04	96,84



### Data sheet

TC4GPN (GP/FG Series)

THERMOLAST® K

#### Product properties

Name TC4GPN

Series GP/FG

Colour / RAL DESIGN Natural

#### Mechanical properties

Hardness 39F +- 5° ShoreA DIN ISO 7619-1

Density 1.100 g/cm3 DIN EN ISO 1183-1

Tensile strength<sup>1</sup> 6,5 MPa DIN 53504/ISO 37

Elongation at break<sup>1</sup> 800 % DIN 53504/ISO 37

Tear resistance 14,0 N/mm ISO 34-1 Methode B (b)(Graves)

CS 72 h/23 °C 12 % DIN ISO 815-1 Method A

CS 24 h/70 °C 23 % DIN ISO 815-1 Method A

CS 24 h/100 °C 59 % DIN ISO 815-1 Method A

<sup>1</sup> Deviating from ISO 37 standard test piece S2 is tested with a traverse speed of 200 mm/min.

All values published in this data sheet are rounded average values.





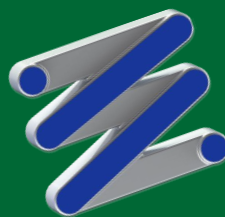

# Ref. SE-TS-80 V 150

## Installation

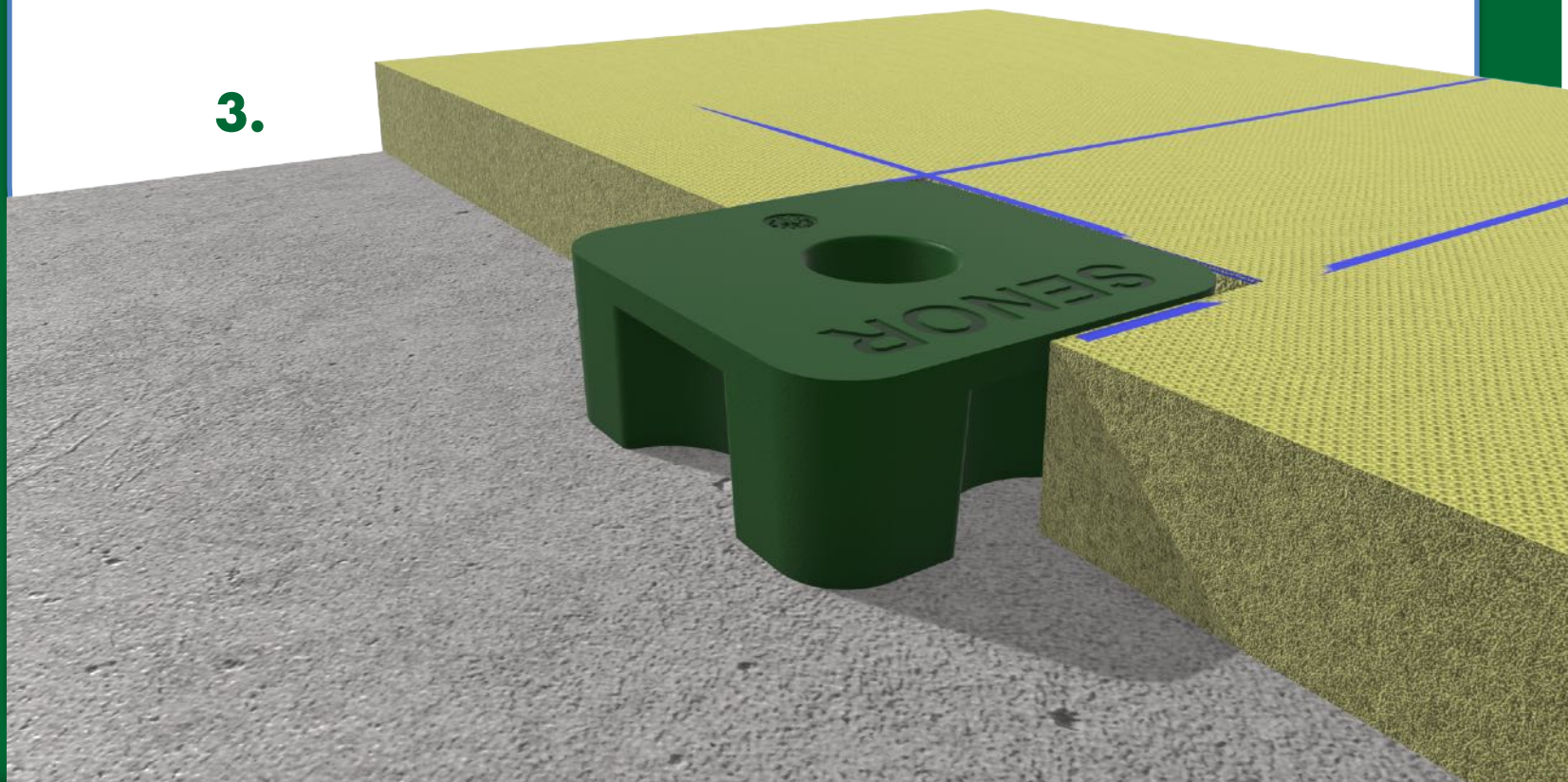
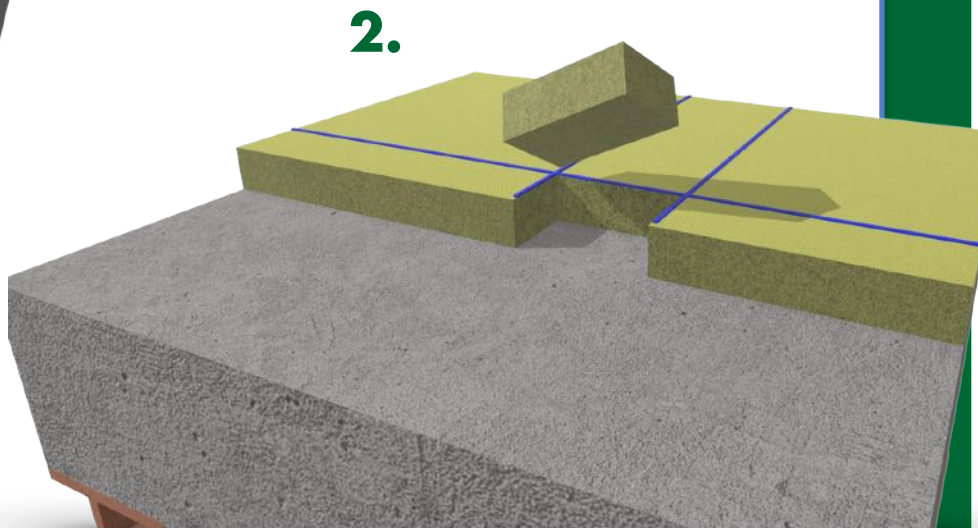
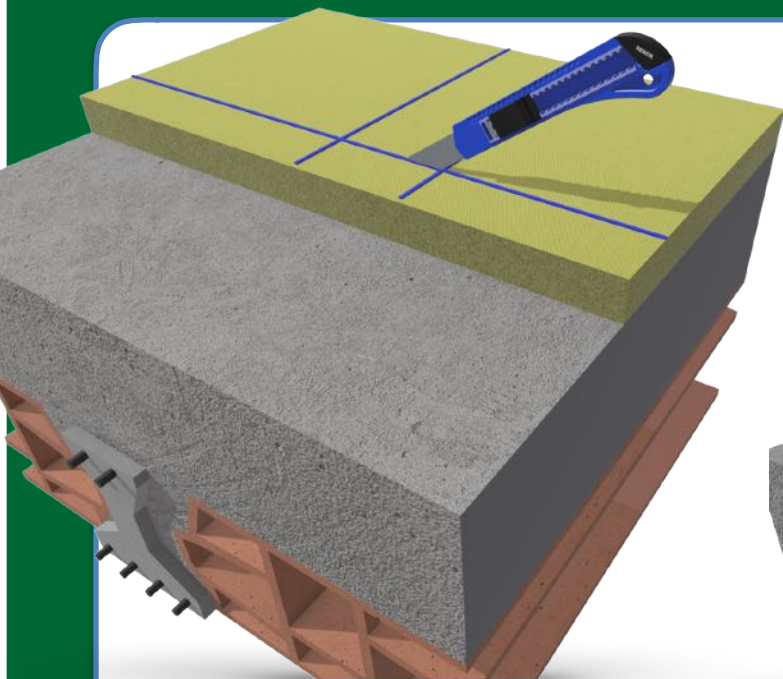



## TS-80 A 280

### RUBBER MOUNT WITH RESTRAINT SYSTEM FOR ACOUSTIC FLOORS OR INERTIA BASES

This model is a **RUBBER** wall mount for acoustic floors devised to provide quality to any given acoustic system and to eradicate sound frequencies and vibrations.

The **SE-TS-80 A 280** includes a **PATENTED** restraint system (two protrusions in its base) which limits the movement making sure the grip to the floor. It is designed in the shape of trapezium with **X** shaped base improving the elasticity of the system and proving an excellent performance in the soundproofing field.



## TS-80 A 280

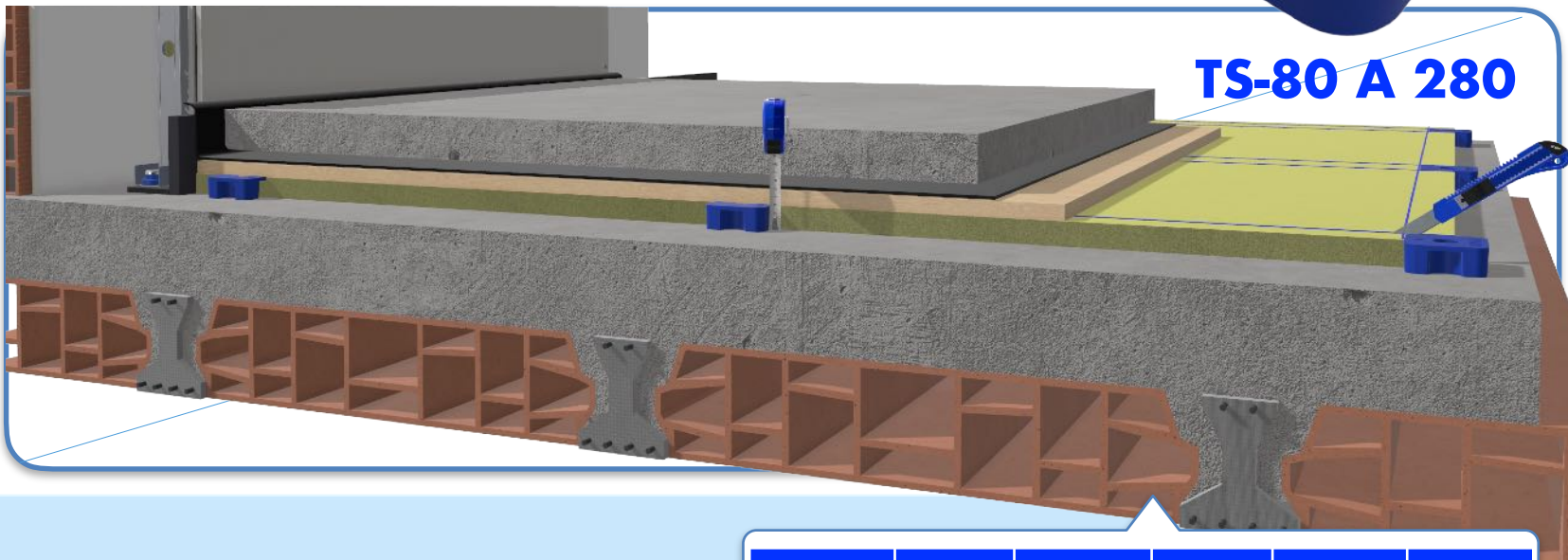

**Suggested use:** rubber mount for acoustic floors under **concrete slab**. This type of polymer has a better damping result than other rubbers such as polyurethane, polystyrene, EPDM, among others.

REF	COLOUR	THICKNESS (mm)	USE	LOAD (kg) MIN-MAX	PACKING (Units)
SE-TS-80 A 280		30	Acoustic floors	150 - 280	16 - 50



**I+D+i**

\*This product has been registered in the **Spanish Patents and Trademarks Office**

#### Quality of the polymer

- Polymer: **KRAIBURG-TPE - TC5/EXN** (tested according to the Standard **UNE-EN ISO 10846-1:2009**).

- ✓ Resonance frequency: **7-15 Hz**.
- ✓ Recommended load range: **150 kg - 280 kg**.



# Ref. SE-TS-80 A 280

## Predicción de Impacto Sonoro (v8.0.1)

Derechos de autor del programa Marshall Day Acoustics 2014

- Key No. 6719

Margen de error de Predicción de Impacto Sonoro está generalmente entre  $L_{n,w} \pm 5$  dB



frecuencia (Hz)	Ln(dB)	Ln(dB)
50	39	
63	38	43
80	37	
100	36	
125	34	40
160	34	
200	34	
250	35	40
315	35	
400	33	
500	32	37
630	30	
800	27	
1000	24	30
1250	22	
1600	19	
2000	15	21
2500	12	
3150	8	
4000	5	11
5000	2	

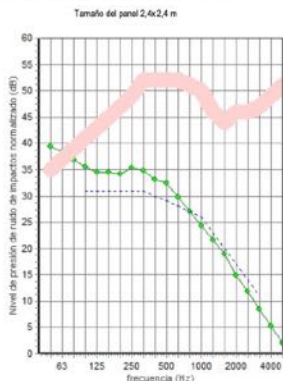

$L_{n,w}$  29 dB  
 $C_1$  0 dB

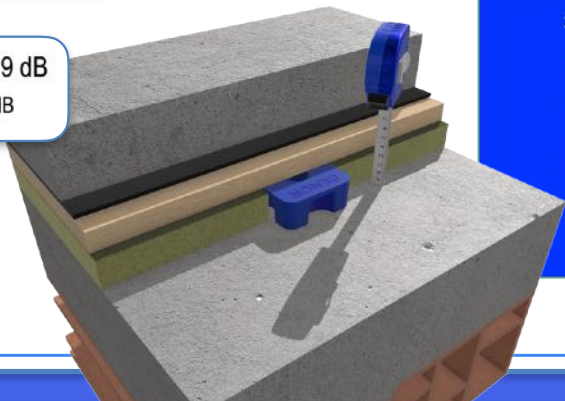

## Laboratory test UNE-EN ISO 10846-1:2009

### STATIC LOAD DEFORMATION

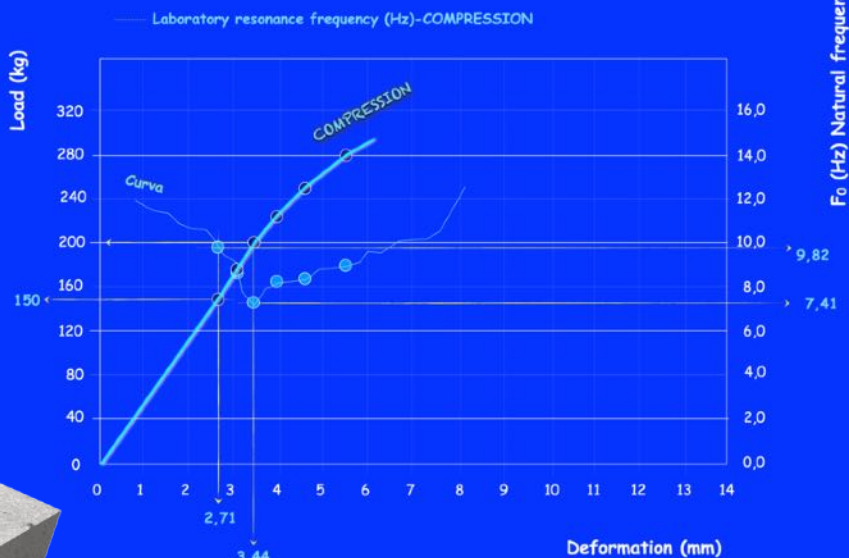

### Axial compression results

LOAD (kg)	DEFORMATION (mm)	RESONANCE FREQUENCY (Hz)	SWEEP (Hz)		SOUNDPROFING LEVEL (%)	
150	2,71	9,82	25	50	81,76	95,99
175	3,10	8,75	25	50	86,04	96,84
200	3,44	7,41	25	50	90,37	97,75
225	3,92	8,02	25	50	88,53	97,36
250	4,62	8,25	25	50	87,78	97,20
280	5,50	8,90	25	50	85,49	96,73



TC5EXN

THERMOLAST® K

#### Products properties

Name of the product TC5EXN

Colour / RAL DESIGN Blue

Processing method Extrusion, Injection Molding

#### Mechanical properties

Hardness 46 +- Shore A DIN ISO 7619-1

Density 1.176 g/cm<sup>3</sup> DIN EN ISO 1183-1

Tensile Strength<sup>1</sup> 6.3 MPa DIN 53504/ISO 37

Elongation at Break<sup>1</sup> 825 % DIN 53504/ISO 37

<sup>1</sup>Deviating from ISO 37 standard test piece S2 is tested with a traverse speed of 200 mm/min.

All values published in this data sheet are rounded average values.







# Ref. SE-TS-80 A 280

## Installation

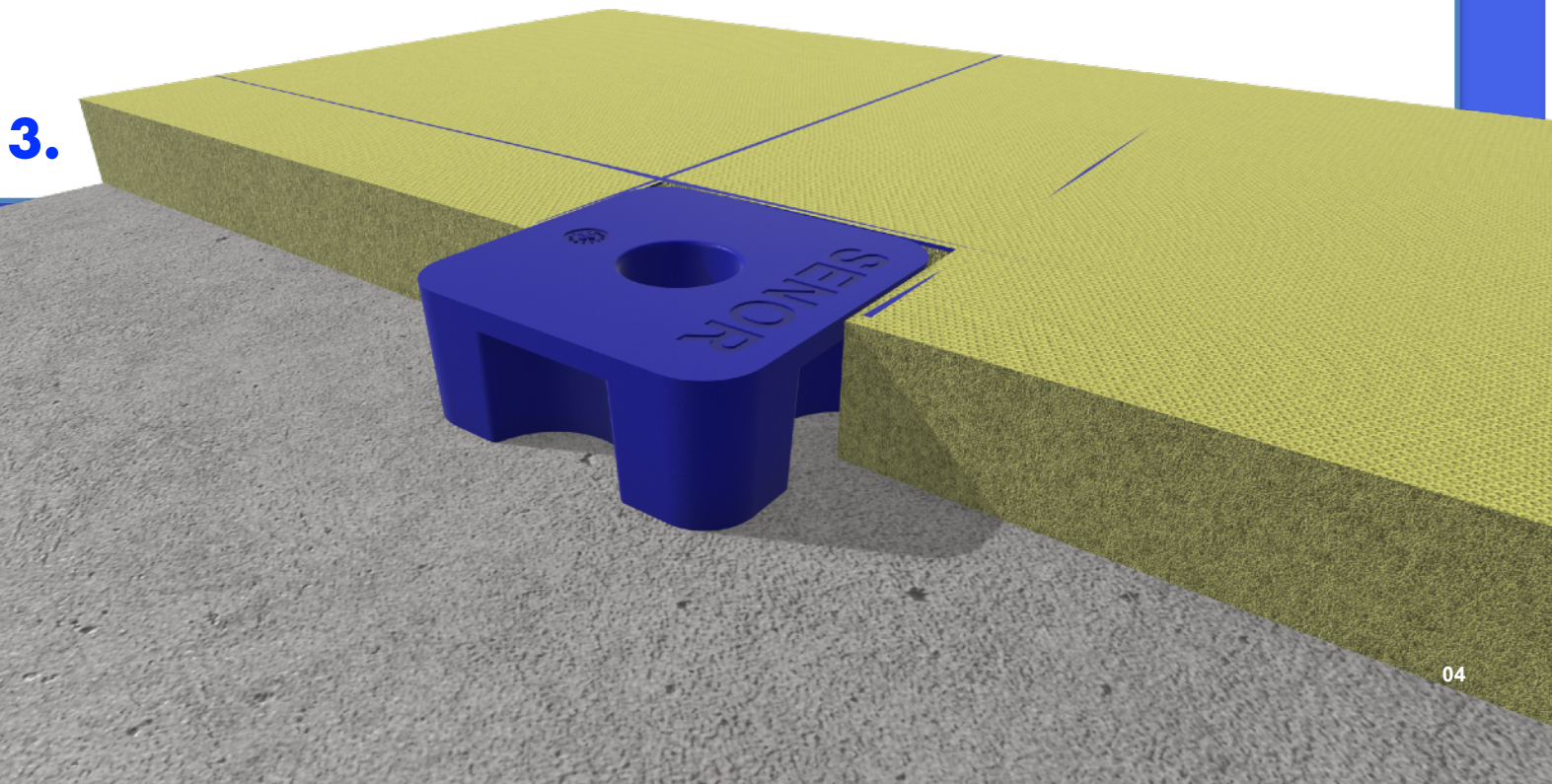
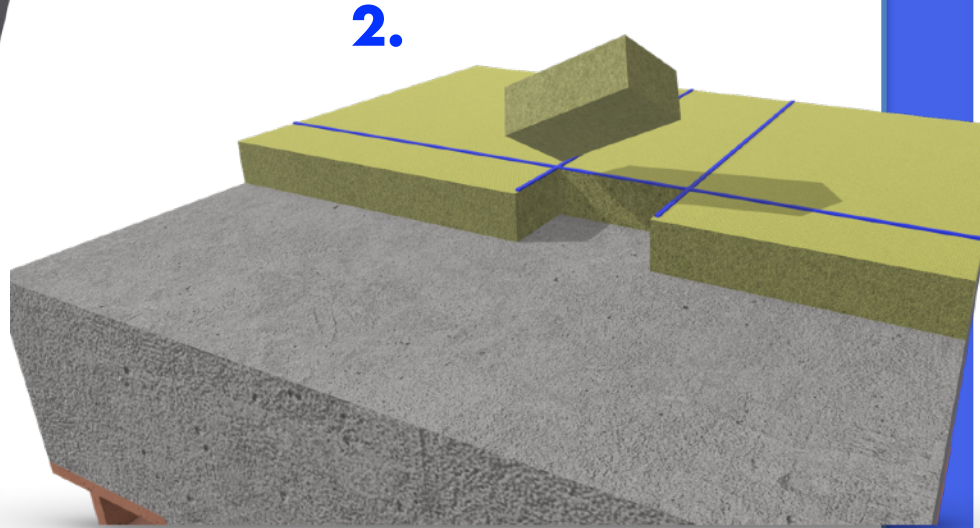
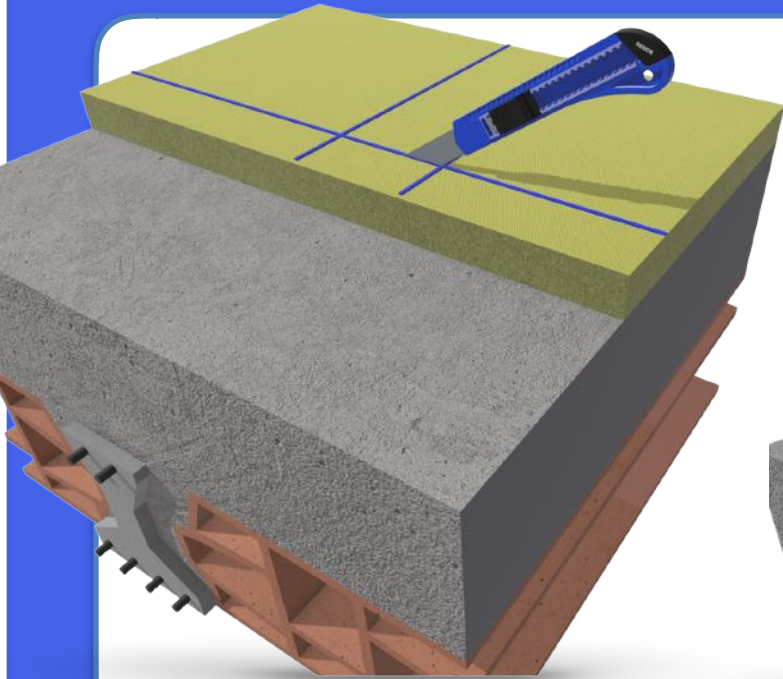



## TS-80 R 400

### RUBBER MOUNT WITH RESTRAINT SYSTEM FOR ACOUSTIC FLOORS OR INERTIA BASES

This model is a **RUBBER** wall mount for acoustic floors devised to provide quality to any given acoustic system and to eradicate sound frequencies and vibrations.

The **SE-TS-80 R 400** includes a **PATENTED** restraint system (two protrusions in its base) which limits the movement making sure the grip to the floor. It is designed in the shape of trapezium with **X** shaped base improving the elasticity of the system and proving an excellent performance in the soundproofing field.

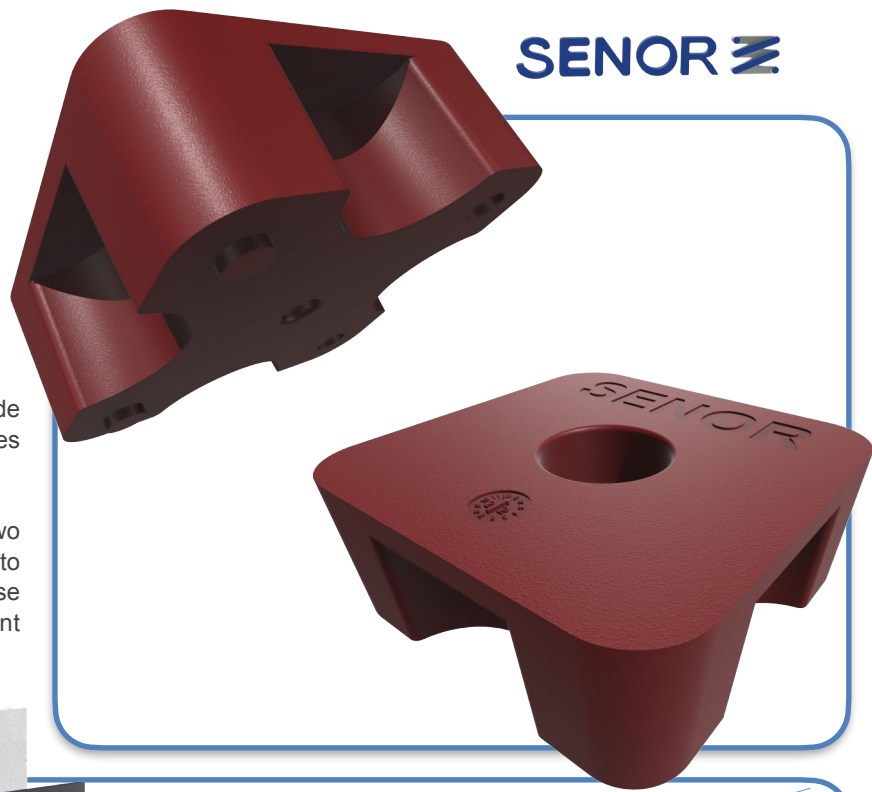

## TS-80 R 400

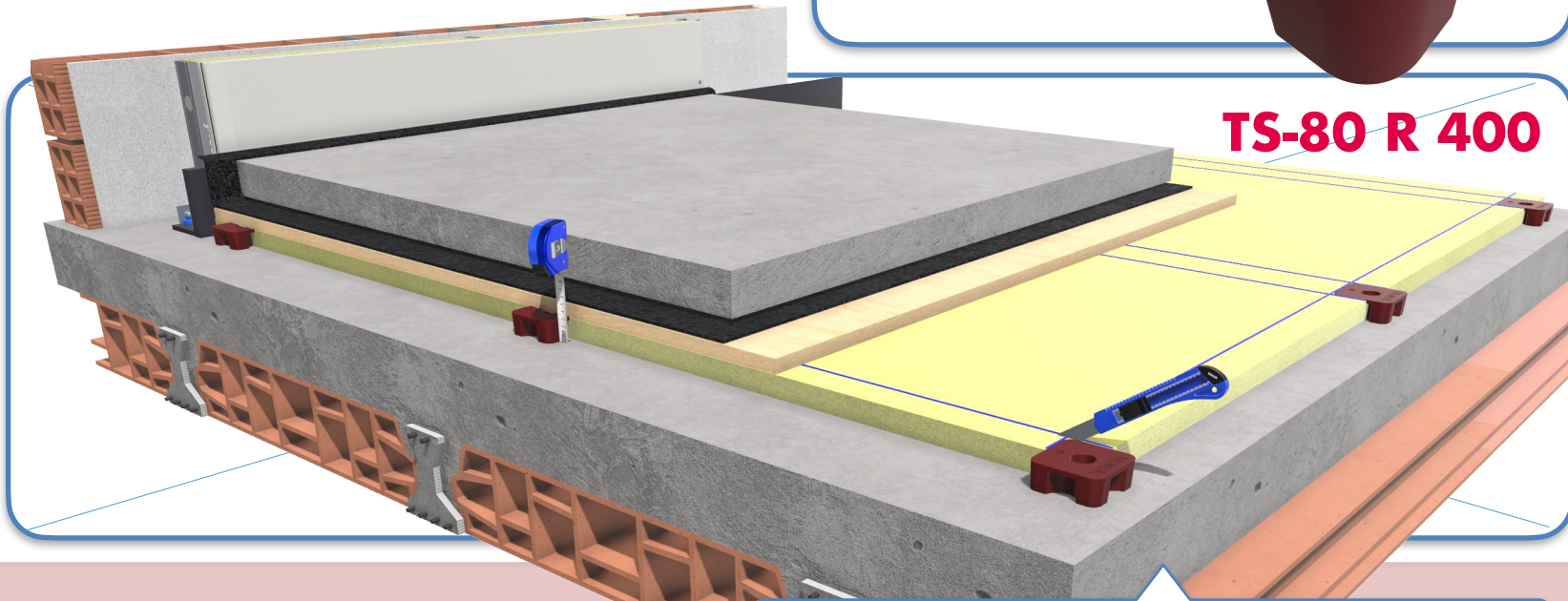

**Suggested use:** rubber mount for acoustic floors under **concrete slab**. This type of polymer has a better damping result than other rubbers such as polyurethane, polystyrene, EPDM, among others.

REF.	COLOUR	THICKNESS (mm)	USES	LOAD (kg) MIN-MAX	PACKING (units)
SE-TS-80 R 400		30	Acoustic floors	270 - 400	16 - 50

SCAN ME



**I+D+i**

\*This product has been registered in the

Spanish Patents and Trademarks Office

#### Quality of the polymer:

● Polymer: **KRAIBURG-TPE - TC5/EXN** (tested according to the Standard UNE-EN ISO 10846-1:2009).

✓ Resonance frequency: **7-15 Hz**

✓ Recommended load range: **270 kg - 400 kg.**

# Ref. SE-TS-80 R 400

## Predicción de Impacto Sonoro (v8.0.1)

Derechos de autor del programa Marshall Day Acoustics 2014

- Key No. 6719

Margen de error de Predicción de Impacto Sonoro está generalmente entre  $L_{n,w} \pm 5$  dB



frecuencia (Hz)	Ln(dB)	Ln(dB)
50	40	
63	39	44
80	38	
100	36	
125	35	40
160	35	
200	35	
250	37	41
315	37	
400	34	
500	32	37
630	30	
800	27	
1000	24	30
1250	22	
1600	19	
2000	15	21
2500	12	
3150	8	
4000	5	11
5000	2	

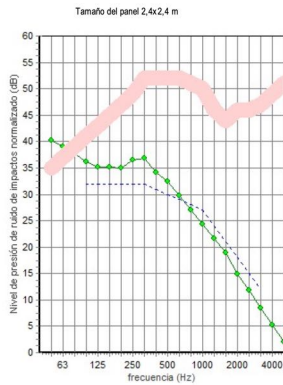

## Laboratory test UNE-EN ISO 10846-1:2009

### STATIC LOAD DEFORMATION

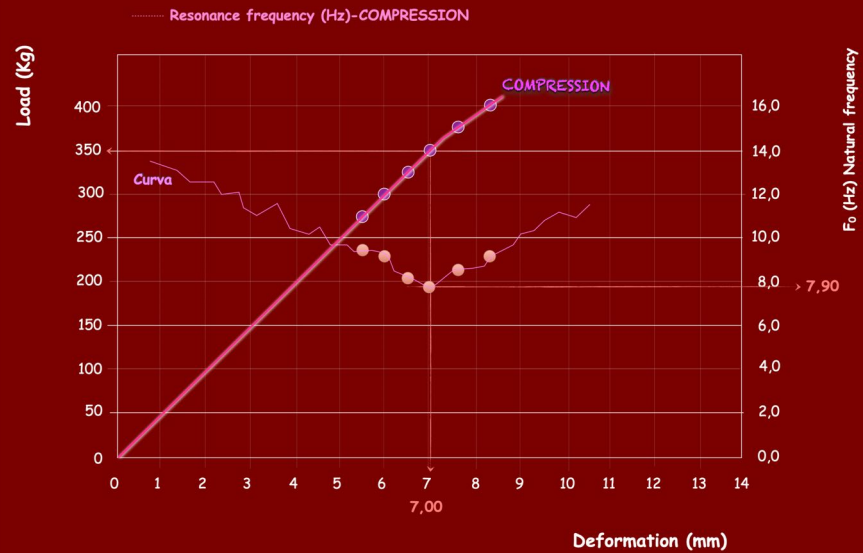

$L_{n,w}$  30 dB  
 $C_1$  0 dB



### Axial compression results

LOAD (Kg)	DEFORMATION (mm)	RESONANCE FREQUENCY (Hz)	SWEEP (Hz)		SOUNDPROOFING LEVEL (%)	
			25	50		
275	5,51	9,50	25	50	83,12	96,25
300	6,02	9,25	25	50	84,14	96,46
325	6,56	8,05	25	50	88,43	97,34
350	7,05	7,90	25	50	88,91	97,44
375	7,56	8,30	25	50	87,61	97,17
400	8,22	9,25	25	50	84,14	96,46



Datasheet

TC6EXN		THERMOLAST® K
<b>Product</b>		
Compound	TC6EXN	
Color / RAL	Rojo	
Processing	Extrusion, Injection	
<b>Mechanical</b>		
Hardne	58° + 5° Shore A	DIN ISO 7619-1
Density	1.190 g/cm <sup>3</sup>	DIN EN ISO 1183-1
Tensile Strength <sup>1</sup>	7.0 MPa	DIN 53504/ISO 37
Elongation at Break <sup>1</sup>	675 %	DIN 53504/ISO 37
Tear Resistance	19.0 N/mm	ISO 34-1 Methode B (b)

<sup>1</sup>Deviating from ISO 37 standard test piece S2 is tested with a traverse  
All values published in this data sheet are rounded average values.



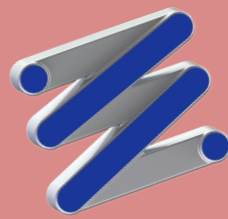

1º- Concrete slab **HA-20** 15x15x10 with a thickness of 120 cm .  
Density: >2450 kg/m<sup>3</sup>.

2º- **ViscoLAM-65** with a thickness of 4 mm. Density: <1650 kg/m<sup>3</sup>.

3º- **MDF Board** with a thickness of 19 mm. Density:>650 kg/m<sup>3</sup>.

4º- Mineral wool (Arena APTA) with thickness of 30 mm. Density < 30 kg/m<sup>3</sup>.

5º- **TS-80 R 400**.

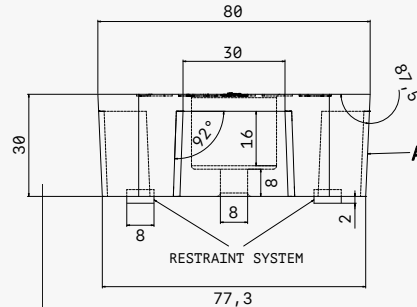
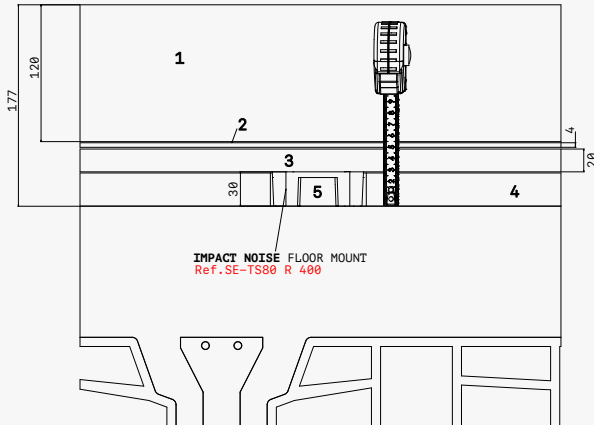

FRONT  
VIEW

PLANT  
VIEW

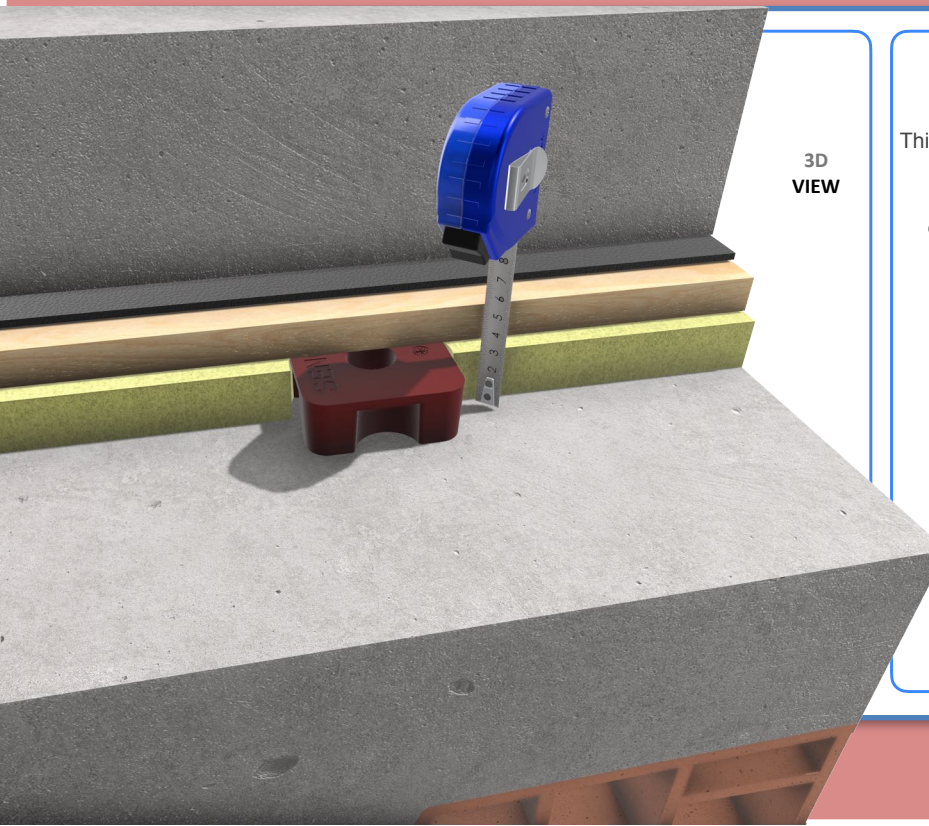
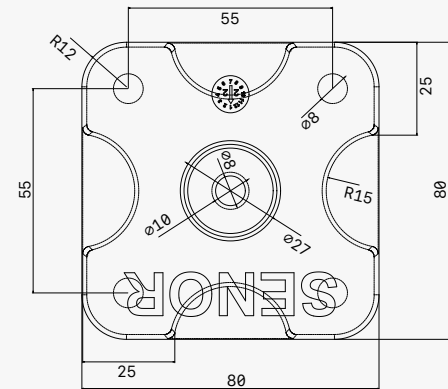

3D  
VIEW

### MATERIALS

This acoustic mount is composed of:

- A: The polymer: **KRAIBURG-TPE - TC6-EXN**. Hardness: 58 +- 5° SHORE A. Colour: **red**. Hardness according to the standard **ISO 48-4** o **DIN ISO 7619-1**

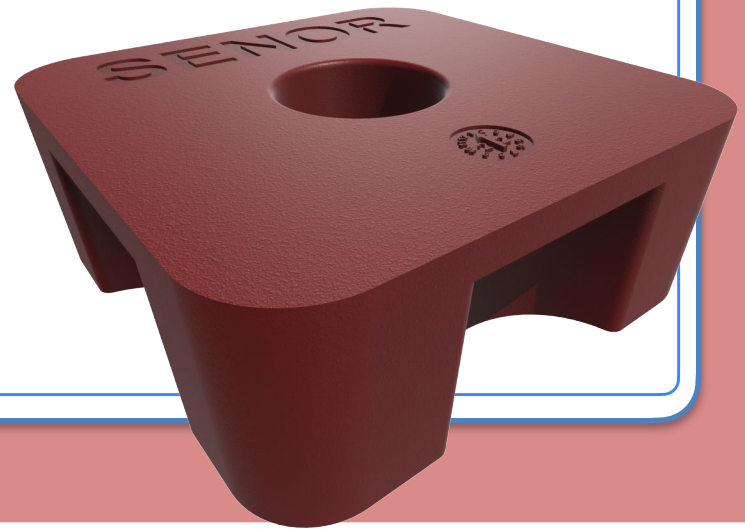



# Ref. SE-TS-80 R 400

## Installation

