



LURRALDE PLANGINTZA, ETXEBIZITZA  
ETA GARRAIO SAILA  
Etxebizitza, Lurzoru eta Arkitektura Zuzendaritza  
Eraikuntzaren Kalitate Kontrolerako Laborategia

DEPARTAMENTO DE PLANIFICACIÓN  
TERRITORIAL, VIVIENDA Y TRANSPORTES  
Dirección de Vivienda, Suelo y Arquitectura  
Laboratorio de Control de Calidad de la Edificación

AKUSTIKA ARLOA kudeatzailea:  
ÁREA DE ACÚSTICA operated by:



## Test Report No. B2020-LACUS-IN-122-2 A\_En

Laboratory measurement of sound insulation

**TEST SPECIMEN:** ACOUSTIC SELF-SUPPORTING WALL LINING (SEÑOR + CHOVA)  
SE-BEC-6X100  
SE-TAV-500/11A  
SE-TAV-500/11R  
SE-BEC-10X100  
SE-MONT-BICAPA-40  
SE-3802/03 TD1  
CHOVANAPA  
CHOVA VISCOLAM

**APPLICANT:** SUSPENSIONES ELÁSTICAS DEL NORTE, S.L. (SEÑOR)  
Polígono industrial El Garrotal, Parcela 10 - Módulos 4 y 5  
14700 Palma del Río, Córdoba, España

**USED STANDARDS:** EN ISO 10140-1:2016 Annex G. "Acoustical linings. Improvement of airborne sound insulation".  
EN ISO 10140-2:2010. "Acoustics. Laboratory measurement of sound insulation of building elements. Measurement of airborne sound insulation".

**ISSUE DATE:** 3<sup>rd</sup> March 2021

**TRANSLATION DATE:** 30<sup>th</sup> April 2021

**Signature:**

Technical Consultant  
Susana Lopez de Aretxaga

The technical ownership of the ENAC Nº4/LE456 accreditation falls to Fundación Tecnalia Research & Innovation, the same way as the technical signatures of this report. The test is performed by personnel of TECNALIA (Industry Lab\_services Area).

Facilities where measurements are carried out under the scope of ENAC Nº4/LE456 accreditation belong to the Acoustic Area of the Building Quality Control Laboratory of the Basque Government, placed at Agirrelanda Street, 10, 01013 Vitoria – Gasteiz (Spain).

**THIS REPORT CONTAINS:**

Total number of pages: 14



This document concerns only and exclusively the test specimen(s) and the moment and conditions in which those measurements were made.

TECNALIA does not take responsibility for the information supplied by the applicant.

This document is the English version of the original report issued in Spanish, B2020-LACUS-IN-122-2 A (3<sup>rd</sup> March 2021). In case of lawsuit, the original document will be taken as reference.

Partial reproduction of this document is expressly forbidden, except with a written conformity from TECNALIA.

The test specimen has been subjected to the test asked by the applicant, following the specified procedures in the used standards.

Test results are detailed in the inside pages. Uncertainty of measurement is available to the applicant.



**1. TEST SPECIMEN DESCRIPTION**

The test specimen consists of a wall lining, with the following composition according to the information provided by the applicant:

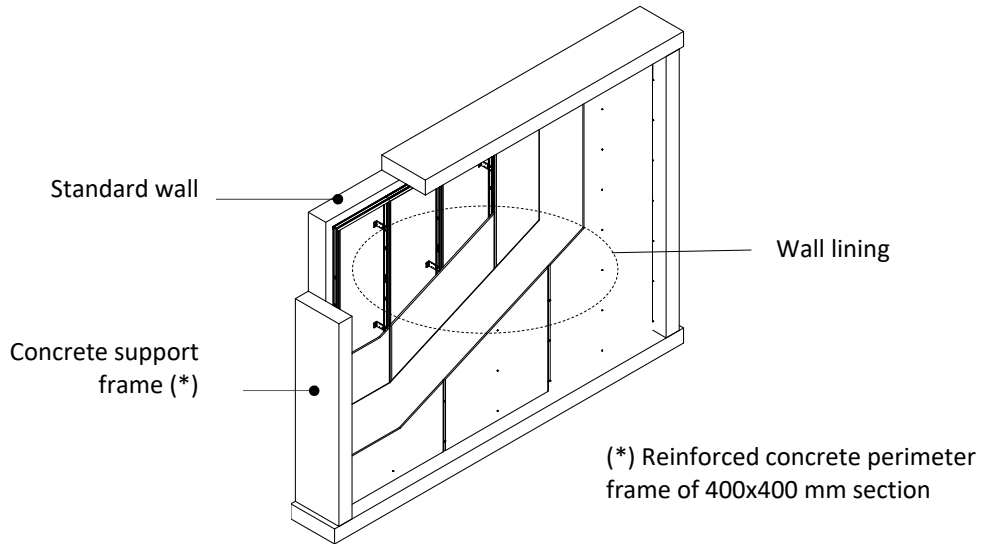

**Sketch 1**

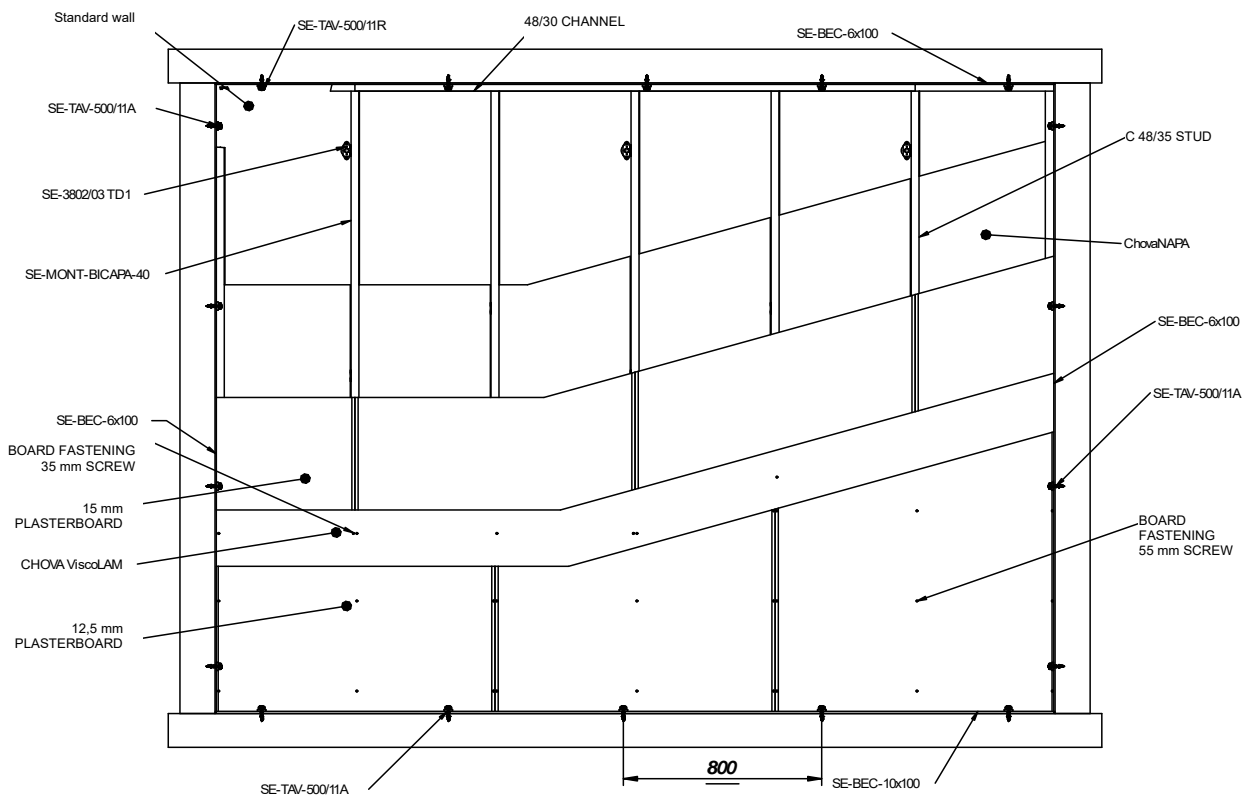

**Sketch 2 (cotes in mm)**



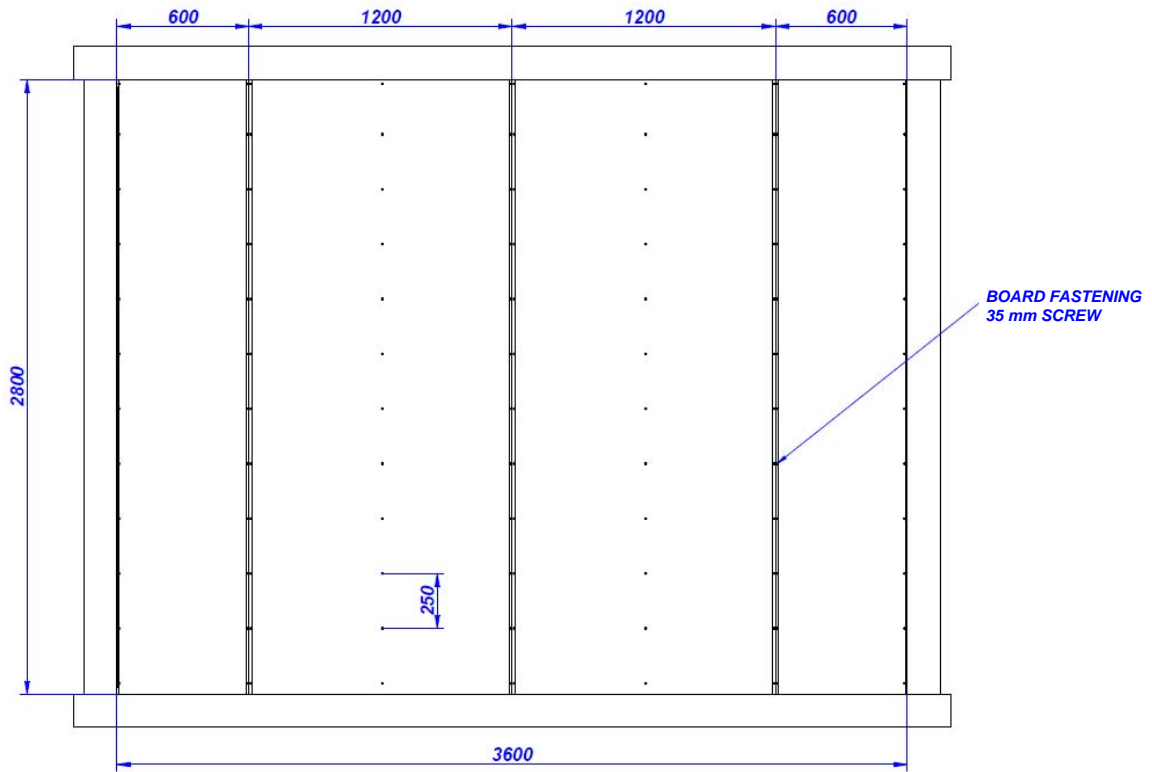

Sketch 4 (cotes in mm)

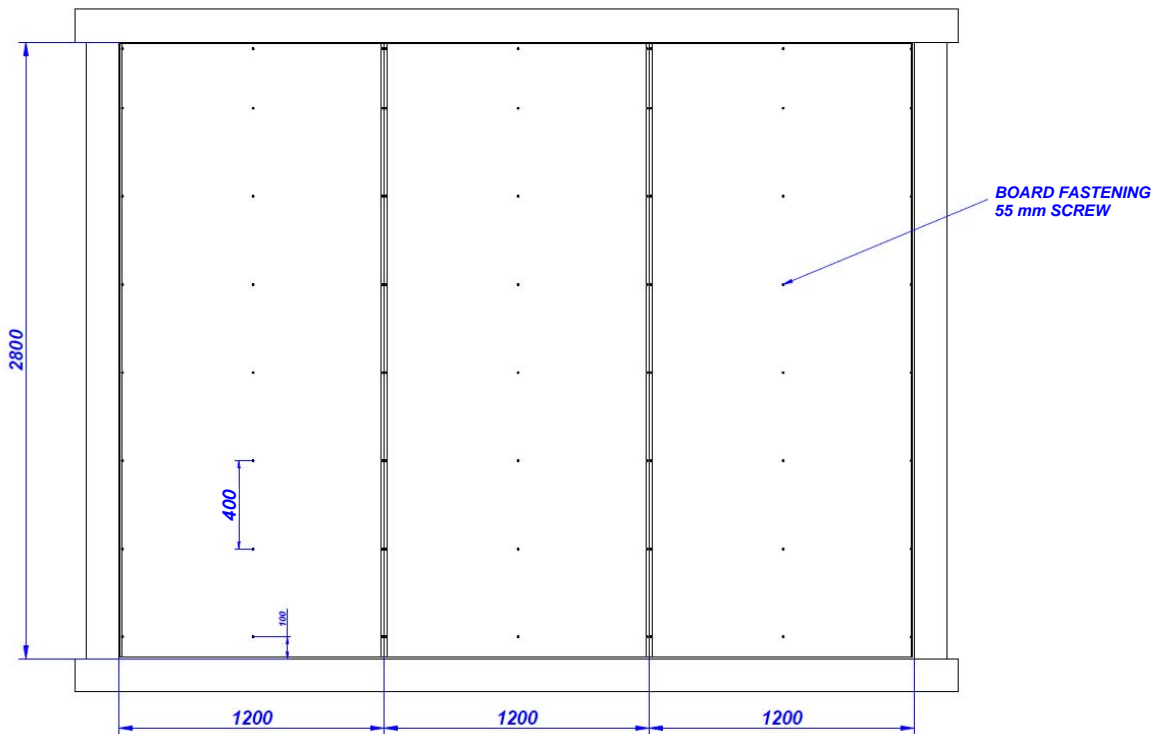

Sketch 5 (cotes in mm)



### Description of materials and details of mounting:

#### Structure:

- SE-BEC-6x100-Senor: EPDM adhesive tape (6 mm thick x 100 mm wide), between upper channel and lateral channels and frame, flush with inner face of channels and adhered to frame.
- SE-BEC-10x100-Senor: EPDM adhesive tape (10 mm thick x 100 mm wide), between lower channel and frame, flush with inner face of channel and adhered to frame.
- 48/30 CHANNEL-Knauf: 48 mm galvanized steel perimeter channel.
- SE-TAV-500/11R-Senor: Isolator for mechanical fixation of upper channel to frame. 5 isolators were used (placed every 800 mm).
- SE-TAV-500/11A-Senor: Isolator for mechanical fixation of lower channel to frame. 5 isolators were used (placed every 800 mm).
- SE-TAV-500/11A-Senor: Isolator for mechanical fixation of lateral channels to frame. 4 isolators were used (placed every 800 mm)
- C 48/35 STUD-Knauf: 46 mm galvanized steel studs, every 600 mm, inserted in channels without mechanical fixation.
- SE-3802/03 TD1-Senor: Damper composed of galvanized steel bracket 120x50x33,5 mm and 0,8 mm and polymer. Mechanically fixed at 2 points to studs and wall, according to sketch 3.
- SE-MONT-BICAPA-40-Senor: 5,5 mm adhesive tape composed of 2,5 mm EPDM + 3 mm cross-linked polyethylene, adhered to channels and studs.

ChovANAPA-Chova: Polyester fiber (40 mm & 15 kg/m<sup>3</sup>). Inserted between studs.

15 mm plasterboard: Gypsum plasterboard Standard BA-STD 15-Knauf (15 mm & 10,5 kg/m<sup>2</sup>). Assembly and mechanical fixation board-profile according to sketch 4. Boards against SEBEC6x100 and SE-BEC-10x100 tapes. Sealing between boards by joint tape and Knauf Unik (30') quick-drying compound.

CHOVA ViscoLAM-Chova: High density viscoelastic membrane ViscoLAM 65 (4 mm & 6,1 kg/m<sup>2</sup>).

Adhered to 15 mm plasterboard by Loctite adhesive and mechanically fixed by the 15 mm and 12,5 mm plasterboards fixing lag screws. 60 mm overlap between sections.

12,5 mm plasterboard: Gypsum plasterboard Standard BA-STD 12,5-Knauf (12,5 mm & 8,1 kg/m<sup>2</sup>).

Assembly and mechanical fixation board-profile according to sketch 5, plus 2 fixings per board to each channel due to out-off-square frame. Boards against SE-BEC-6x100 and SEBEC-10x100 tapes. Sealing between boards and between boards and frame by joint tape and Knauf Unik (30') quick-drying compound. Perimeter sealing plasterboards-SE-BEC tapes by Knauf Unik (30') quick-drying compound.

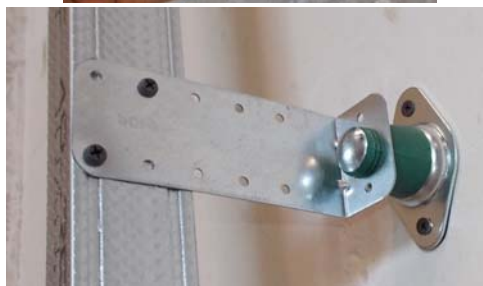
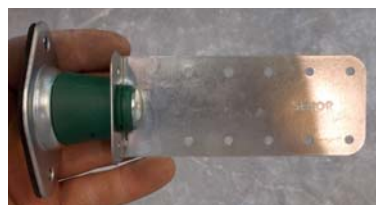



**Photos of mounting of wall lining**



**Photos of wall lining on wall in the test rooms**

Material selected and delivered by: SENOR, ASFALTOS CHOVA, S.A (Chova) and Knaufl; each company its material as indicated in the test specimen description.

**Mounting in the test opening:**

Lining mechanically fixed to standard wall built in a prefabricated concrete frame, 40 cm thick and internal dimensions of 2,8 m high by 3,6 m long.

Mounting performed by: SENOR

Mounting end date: 22<sup>nd</sup> October 2020



### **Standard wall:**

Lined filled block wall, of 300 kg/m<sup>2</sup> estimated superficial mass (\*).

(\*) Filling and mortar joints included.

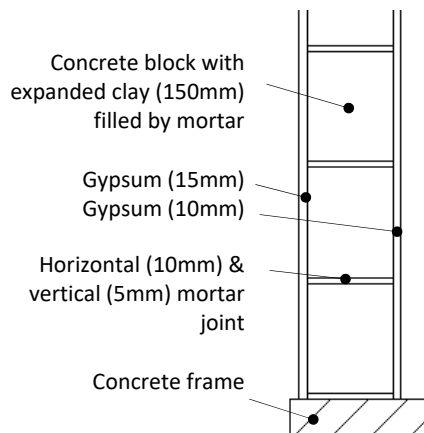

Block: 500 mm long x 190 mm high x 150 mm thick & 14,2 kg (estimated superficial mass: 149 kg/m<sup>2</sup>).

### **Sketch and photos of standard wall**

Standard basic element, 'Heavy wall', according to EN ISO 10140-5:2010, Annex B. Provided by the laboratory in its final condition. 10 mm gypsum side oriented to tested lining.

## **2. TEST FACILITIES**

The test is performed in the horizontal transmission rooms, composed of a source and a receiving room. The receiving room is composed of a double concrete box of twenty and ten centimeters of thickness each one, acoustically disconnected and the source room, forty centimeters thick, is composed of a double box of metal frame and gypsum board, acoustically disconnected. The mobility of the source room allows the mounting of the test specimen into a frame outside, as well its subsequent installation between the test rooms. These rooms comply with the requirements of EN ISO 10140-5:2010.



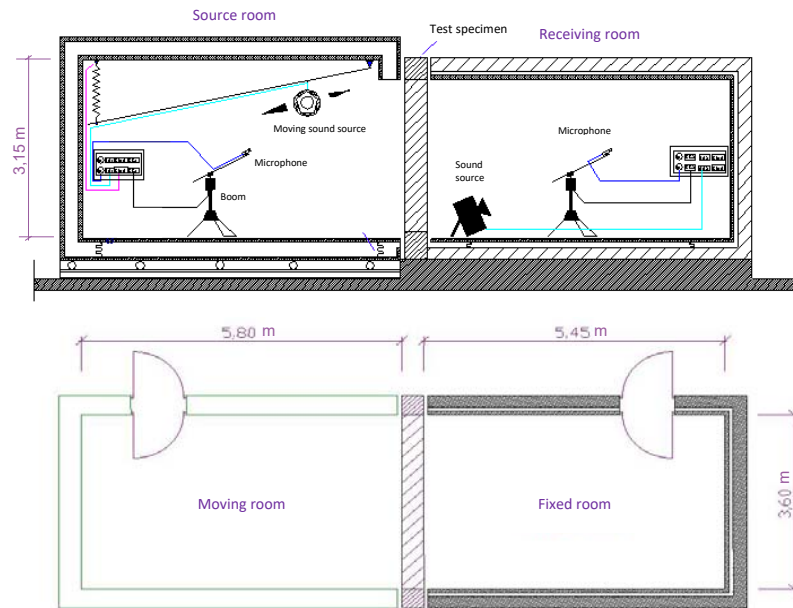

Sketch of horizontal transmission rooms

### 3. EQUIPMENT AND TEST CONDITIONS

	Source Room	Receiving Room
Microphones	Brüel & Kjær 4943; Serial No. 3188436	Brüel & Kjær 4943; Serial No. 3188435
Preamplifiers	Brüel & Kjær 2669; Serial No. 1948764	Brüel & Kjær 2669; Serial No. 2025844
Sound sources	Brüel & Kjær 4296; Serial No. 2071420	CERWIN VEGA; No. 012446
Booms	Brüel & Kjær 3923; Serial No. 2036584	Brüel & Kjær 3923; Serial No. 2036591

	Control Room
Analyser	Nor850-MF1; Serial No. 8501186
Amplifier	LAB 300; Serial No. 970-967
Equalizer	Sony, SRP-E100; Serial No. 400238
Calibrator	Brüel & Kjær 4231; Serial No. 2061477
Atmospheric conditions meter	Rotronic BL-1D; Serial No. A19060062

Measurement uncertainty of atmospheric conditions:	
Air temperature	±0,5 °C
Air humidity	±4 %
Atmospheric pressure	±2 mbar



## 4. TEST PROCEDURE AND EVALUATION

### 4.1 Determination of the sound reduction improvement index of a lining

The improvement of airborne sound insulation of a lining is characterized by the sound reduction improvement index ( $\Delta R$ ). For its determination, the measurement of airborne sound insulation is performed according to EN ISO 10140-2:2010, both for the basic element and basic element + lining.

The sound reduction improvement index ( $\Delta R$ ) of a lining placed on a basic element, for the one-third octave band from 100 Hz to 5 kHz, is obtained according to standard EN ISO 10140-1:2016 - Annex G, as the difference between the sound reduction indices of the basic element with and without the lining, as detailed in the equation:

$$\Delta R = R_{\text{with}} - R_{\text{without}}$$

$R_{\text{with}}$ : Sound reduction index of the basic element with lining, from 100 to 5000 Hz

$R_{\text{without}}$ : Sound reduction index of the basic element without lining, from 100 to 5000 Hz

### 4.2 Determination of the airborne sound insulation

The sound reduction index,  $R$ , for the one-third octave band from 100 Hz to 5 KHz is calculated according to EN ISO 10140-2:2010 using the following formula:

$$R = L_1 - L_2 + 10 \cdot \log S/A$$

$L_1$ : Average sound pressure level in the source room

$L_2$ : Average sound pressure level in the receiving room

$S$ : Test specimen area

$A$ : Equivalent sound absorption area in the receiving room

The measurement of the average sound pressure levels  $L_1$  and  $L_2$  is performed by emitting an equalized white noise, from 100 Hz to 5 kHz, using a moving omnidirectional sound source. The sound field in the source and receiving rooms is sampled using a moving microphone with a sweep radius of 1 m and a traverse period of 16 s during 32 s of measure. Background noise in the receiving room for the one-third-octave band from 100 Hz to 5 KHz, is measured according to the same measurement process of sound field in the receiving room.

The equivalent sound absorption area, from 100 Hz to 5 kHz, is evaluated from the reverberation time measured in the receiving room, using Sabine's formula:

$$A = 0,16 \cdot V/T$$



- A: Equivalent sound absorption area in the receiving room
- T: Reverberation time in the receiving room
- V: Receiving room volume

Reverberation time in the receiving room is determined by using two positions of the sound source and three fixed microphone positions for each source position distributed at 120° in the microphone path.

Measuring chain is verified just before and after the execution of the test.

The guidelines indicated in the applicable internal procedures have been followed:

- PE.CM-AA-61-E: “Procedure for the determination of the airborne sound insulation into the horizontal and vertical transmission rooms”.
- PE.MC-AA-06-M: “Procedure to manage the test specimens for acoustic tests in laboratory”.

Standard EN ISO 10140-2:2010, together with the other EN ISO 10140-1:2016, EN ISO 10140-4:2010 and EN ISO 10140-5:2010, cancels and replaces EN ISO 140-3:1995. The measurement and evaluation process applied to the test specimen described in this report is according to the standard in force EN ISO 10140-2:2010, and complies with cancelled EN ISO 140-3:1995.

## 5. RESULTS

The following results are presented:

### **B2020-122-M758 MRA: Sound reduction improvement index of *Lining on the standard basic element 'heavy wall'*:**

- Sound reduction improvement index,  $\Delta R$ , in decibels, for the one-third-octave band from 100 Hz to 5000 Hz, in table and graph.
- Weighted sound reduction improvement index,  $\Delta R_{w,heavy}$ , calculated according to EN ISO 10140-1:2016, Annex G, on the standard heavy wall.

$$\Delta R_{w,heavy} = R_{w,ref,with} - R_{w,ref,without}$$

$$R_{ref,with} = R_{ref,without} + \Delta R$$

$R_{ref,without}$  given in EN ISO 10140-5:2010, Annex B.

- A-weighted improvement of sound reduction indices  $\Delta(R_w+C)_{heavy}$  and  $\Delta(R_w+C_{tr})_{heavy}$ , calculated in an equivalent way.



- A-weighted improvement of sound reduction indices  $\Delta(R_w+C_{100-5000})_{\text{heavy}}$  and  $\Delta(R_w+C_{\text{tr},100-5000})_{\text{heavy}}$ , calculated in an equivalent way.

Additionally, are presented:

- Sound reduction index of the standard wall with lining,  $R_{\text{with}}$ , for the one-third-octave band from 100 Hz to 5000 Hz.
- Sound reduction index of the standard wall without lining,  $R_{\text{without}}$ , for the one-third-octave band from 100 Hz to 5000 Hz.
- Global indices  $R_w(C; C_{\text{tr}})$ ,  $R_A$  and  $R_{A,\text{tr}}$  for the both elements mentioned above.

### **B2020-122-M758 RA: Airborne sound insulation of Lining + 'heavy wall':**

- Sound reduction index,  $R$ , for the one-third octave band from 100 to 5000 Hz, in table and graph.
- Global indices  $R_w(C; C_{\text{tr}})$ ,  $R_A$  and  $R_{A,\text{tr}}$ .

The global indices  $R_w(C; C_{\text{tr}})$ ,  $R_A$  and  $R_{A,\text{tr}}$  for a test specimen are calculated as follows:

- $R_w$ : Weighted sound reduction index, calculated according to EN ISO 717-1:2013, from the sound reduction index,  $R$ .
- $C$  y  $C_{\text{tr}}$ : Spectrum adaptation terms from 100 to 3150 Hz, calculated according to EN ISO 717-1:2013, which are the values, expressed in decibels, to be added to the global magnitude value  $R_w$  to consider the characteristics of the pink noise spectrum ( $C$ ) and traffic noise spectrum ( $C_{\text{tr}}$ ), respectively.
- $R_A$  and  $R_{A,\text{tr}}$ : Global indices calculated according to the expression of *Documento Básico "DB-HR Protección frente al ruido" - Código Técnico de la Edificación (CTE)*, from the sound reduction index,  $R$ , obtained by laboratory measurement:
  - $R_A$ : A-weighted sound reduction index, from 100 to 5000 Hz, expressed to one decimal place.
  - $R_{A,\text{tr}}$ : A-weighted sound reduction index for exterior traffic noise, from 100 to 5000 Hz, expressed to one decimal place.

The  $R$  value marked with \* means that it is greater than or equal to the indicated value, due to approaching in less than 15 dB to  $R'_{\text{max}}$  of test facilities and due to approaching of the receiving level in less than 6 dB to the background noise (1,3 dB has been made for background correction). Likewise, the  $\Delta R$  value marked with \* means that it is greater than or equal to the indicated value, due to the measurement limit of the  $R$  value marked with \*.

The  $R$  value marked with # means that it is greater than or equal to the indicated value, due to approaching in less than 15 dB to  $R'_{\text{max}}$  of test facilities. Likewise, the  $\Delta R$  value marked with # means that it is greater than or equal to the indicated value, due to the measurement limit of the  $R$  value marked with #.



**Sound reduction improvement index of a lining on standard heavy wall  
according to EN ISO 10140-1:2016 Annex G  
Laboratory measurements according to EN ISO 10140-2:2010**

**Applicant:** SUSPENSIONES ELÁSTICAS DEL NORTE, S.L. (SEÑOR)

**Result No.:** B2020-122-M758 MRA

**Test date:** 23<sup>rd</sup> October 2020

**Test specimen:** ACOUSTIC SELF-SUPPORTING WALL LINING (SEÑOR + CHOVA): SE-BEC-6X100; SE-TAV-500/11A; SE-TAV-500/11R; SE-BEC-10X100; SE-MONT-BICAPA-40; SE-3802/03 TD1; CHOVANAPA; CHOVA VISCOLAM.

**Standard heavy wall:** Lined filled concrete block wall (300 kg/m<sup>2</sup>), tested on 19<sup>th</sup> October 2020 ( $R_{without}$ )

Estimated superficial mass: 25 kg/m<sup>2</sup>

Test specimen area: 10,08 m<sup>2</sup>  $T_{rooms}$ : 20,4 °C

Source room volume: 65,3 m<sup>3</sup>  $HR_{rooms}$ : 53 %

Receiving room volume: 55,2 m<sup>3</sup>  $P_{rooms}$ : 961 mbar

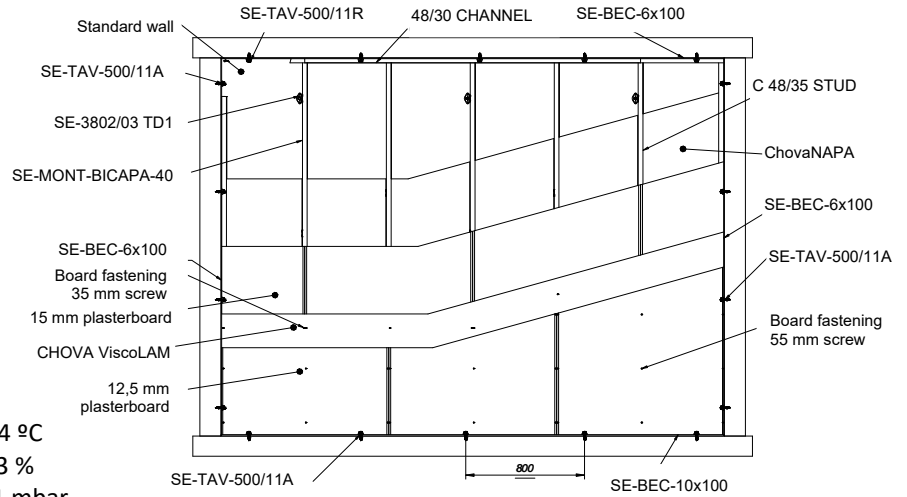

f (Hz)	$R_{with}$ (dB)	$R_{without}$ (dB)	$\Delta R$ (dB)
100	43,8	35,4	8,4
125	44,4	36,0	8,4
160	48,4	34,8	13,6
200	51,9	34,4	17,5
250	50,3	34,2	16,1
315	56,9	38,0	18,9
400	60,1	41,3	18,8
500	65,0	43,2	21,8
630	69,5	46,3	23,2
800	71,9	48,9	23,0
1000	74,4	52,0	22,4
1250	80,5	54,2	26,3
1600	84,2	56,2	28,0
2000	87,7	56,7	31,0
2500	91,8 *	53,9	37,9 *
3150	91,6 *	52,8	38,8 *
4000	84,2 #	53,8	30,4 #
5000	81,8 #	54,3	27,5 #

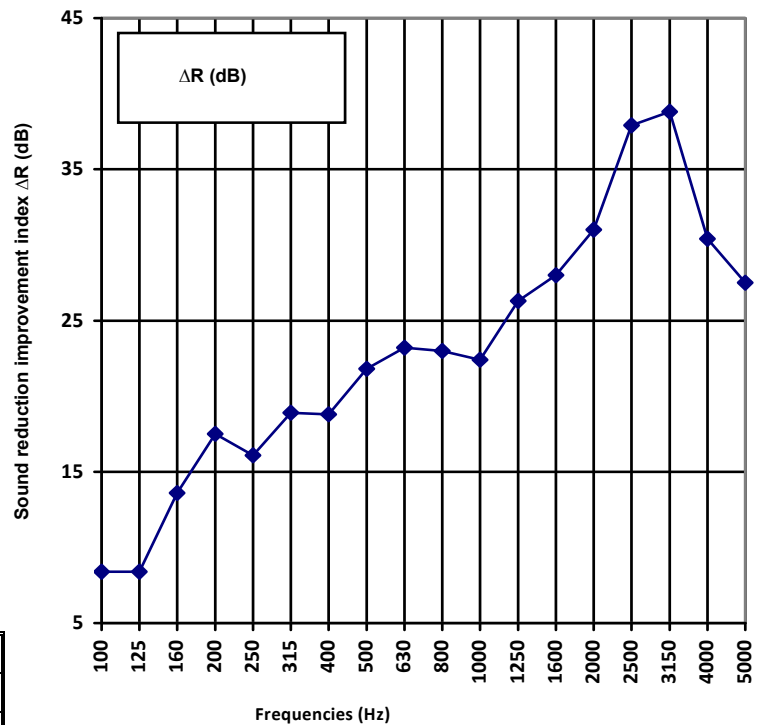

$R_w(C; C_{tr})_{with}$ : 65(-2;-7) dB	$R_w(C; C_{tr})_{without}$ : 48(-2;-5) dB
$R_{A,with}$ : 64,1 dBA	$R_{A,without}$ : 47,1 dBA
$R_{A,tr,with}$ : 57,8 dBA	$R_{A,tr,without}$ : 42,9 dBA

Weighted indices according to EN ISO 10140-1:2016 Annex G:

$$\Delta R_{w,heavy} = 17 \text{ dB} / \Delta(R_w+C)_{heavy} = 16 \text{ dBA} / \Delta(R_w+C_{tr})_{heavy} = 15 \text{ dBA}$$

$$\Delta(R_w+C_{100-5000})_{heavy} = 16 \text{ dBA} / \Delta(R_w+C_{tr,100-5000})_{heavy} = 15 \text{ dBA}$$

Evaluation based on laboratory measurement results obtained by an engineering method

\* $R'$  y  $\Delta R \geq$  indicated value (measurement limit by approx. background and  $R'_{max}$ ).  $R'_{max}$  2500 Hz = 102,4 dB; 3150 Hz = 101,2 dB.  
#  $R'$  y  $\Delta R \geq$  indicated value (measurement limit by approx.  $R'_{max}$ ).  $R'_{max}$ ; 4000 Hz = 96,9 dB; 5000Hz: 94,1dB.





## Airborne Sound Insulation according to EN ISO 10140-2:2010 Laboratory Measurements

**Applicant:** SUSPENSIONES ELÁSTICAS DEL NORTE, S.L. (SENOR)

**Result No.:** B2020-122-M758 RA

**Test date:** 23<sup>rd</sup> October 2020

**Test specimen:** ACOUSTIC SELF-SUPPORTING WALL LINING (SENOR + CHOVA): SE-BEC-6X100; SE-TAV-500/11A; SE-TAV-500/11R; SE-BEC-10X100; SE-MONT-BICAPA-40; SE-3802/03 TD1; CHOVANAPA; CHOVA VISCOLAM, ON LINED BLOCK WALL.

Estimated superficial mass: 325 kg/m<sup>2</sup>

Test specimen area: 10,08 m<sup>2</sup>

Source room volume: 65,3 m<sup>3</sup>

Receiving room volume: 55,2 m<sup>3</sup>

T<sub>rooms</sub>: 20,4 °C

HR<sub>rooms</sub>: 53 %

P<sub>rooms</sub>: 961 mbar

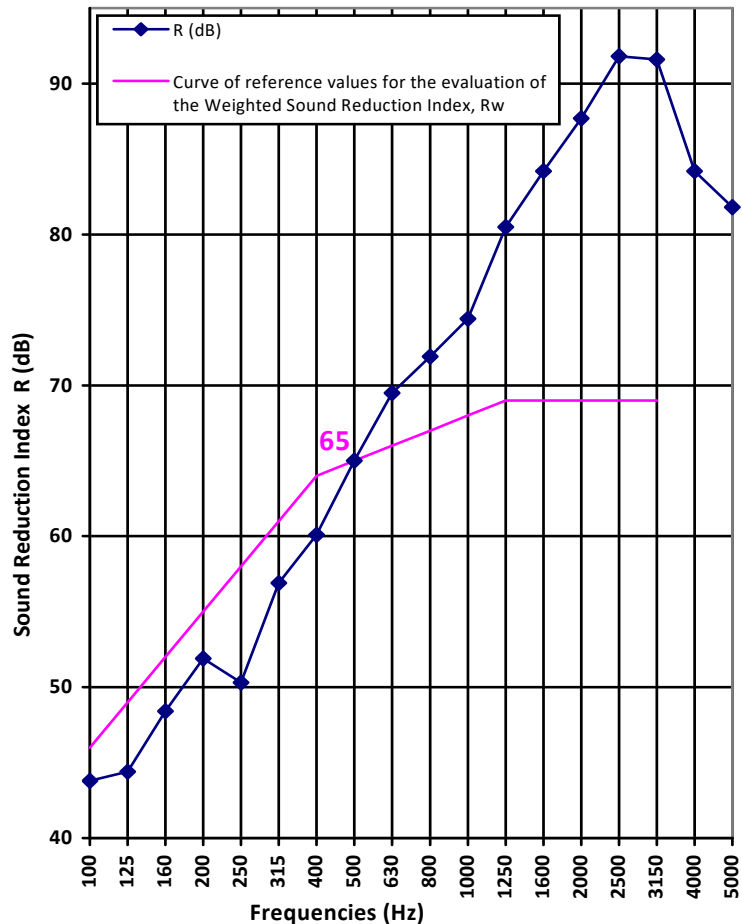
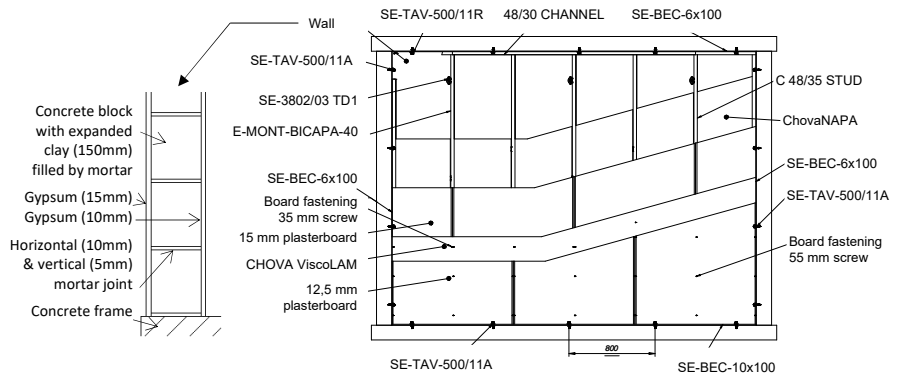

f (Hz)	R (dB)
100	43,8
125	44,4
160	48,4
200	51,9
250	50,3
315	56,9
400	60,1
500	65,0
630	69,5
800	71,9
1000	74,4
1250	80,5
1600	84,2
2000	87,7
2500	91,8 *
3150	91,6 *
4000	84,2 #
5000	81,8 #

Rating according to EN ISO 717-1:2013: R<sub>w</sub> (C;C<sub>tr</sub>): 65 (-2; -7) dB

Rating according to CTE DB-HR: R<sub>A</sub>: 64,1 dBA

R<sub>A,tr</sub>: 57,8 dBA

*Evaluation based on laboratory measurement results obtained by an engineering method*



\*R' ≥ indicated value (measurement limit by approx. background and R'<sub>max</sub>). R'<sub>max</sub> 2500 Hz = 102,4 dB; 3150 Hz = 101,2 dB  
# R' ≥ indicated value (measurement limit by approx. R'<sub>max</sub>). R'<sub>max</sub> 4000 Hz = 96,9 dB; 5000Hz: 94,1dB.