

CONSTRUCTION Catalogue

2021

HYBRID HANGER WITH
DIRECT FASTENING TO PROFILE
STIL PRIM-100

Ref. SE-STRIB CAB 45 V



SENOR

CONSTRUCTION Catalogue 2021

HYBRID HANGER WITH DIRECT FASTENING TO PROFILE STIL PRIM-100

Ref. SE-STRIB CAB 45 V



Introduction

A **DIFFERENT** and **PROFESSIONAL** acoustic hanger. Higher performance in the least space.

They are **HYBRID** hangers with locking stops named **CUG**. Our engineers work every day for your safety.

STRIB CAB 45 V is manufactured with high performance and renovated raw material providing improvements in the vibro-acoustic field.

STRIB CAB 45 V is more than a hanger. It is an acoustic hanger with fast adjustment to first profile **STIL PRIM 100**. The profile is fixed with a simple gesture making him an **innovative and unique** product.

We use the latest technology in the production such as: renovated polymers (**KRAIBURG-TPE**) tested according to **UNE-EN ISO 10846-1:2009** and placed in the sides on the steel spiral. The steel spring is manufactured according to **DIN 2095 UNE EN 10270**, with **GREEN EPOXY** treatment.





CONSTRUCTION Catalogue 2021

HYBRID HANGER WITH DIRECT FASTENING TO PROFILE STIL PRIM-100

Ref. SE-STRIB CAB 45 V

N° PT
U. 009901248



ACOUSTIC / HYBRIDE Ceiling

STEEL SPRING: it provides a high level of insulation to **vibrations** in the range of **low/medium frequencies** (Hz).

RENOVATED POLYMERS: they have a higher damping factor and allow a better insulation to **vibration** in the range of **medium/high** frequencies (Hz).

COMBINATION: the combination makes possible launch onto the market the best acoustic hanger of the moment and reduce the vibrations in the range of **exciter frequencies**.

It is available in several metrics: 6, 8 and 10.

LOAD RANGE (KG)

It is recommended to loads between
15 kg and **45 kg** (maximum load).

(Strongly recommended not to exceed this limit
in order to prevent overstressing the polymer).

RESONANCE frequency: **3-7 Hz**.

N° PT

U. 009901248

HYBRID HANGER WITH DIRECT FASTENING TO PROFILE STIL PRIM-100

Ref. SE-STRIB CAB 45 V

Manufacturer of **ANTIVIBRATION** systems

LABORATORY Test. UNE-EN ISO 10846-1:2009

Acoustic and vibration. Measurement in the laboratory of vibro-acoustic transfer properties of elastic elements.

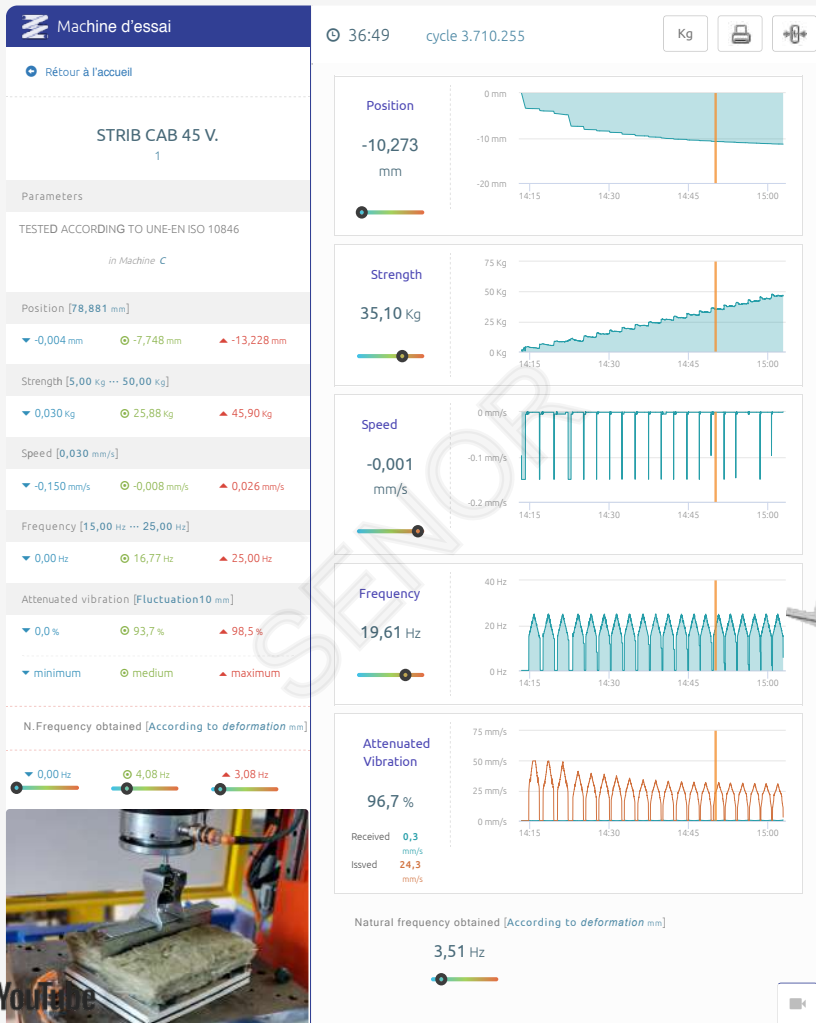

(D¹)

Internal **Axial**
Compression



HYBRID HANGER WITH DIRECT FASTENING TO PROFILE STIL PRIM-100

Ref. SE-STRIB CAB 45 V

LABORATORY RESULTS

Chart 1

ACOUSTIC / HYBRID Ceiling



GREEN RUBBER & SPRING:
Available references

- 1° SE-STRIB CAB 45 V/M6.
- 2° SE-STRIB CAB 45 V/M8.
- 3° SE-STRIB CAB 45 V/M10.

N° PT
U. 009901248

CONSTRUCTION Catalogue 2021

HYBRID HANGER WITH DIRECT FASTENING TO PROFILE STIL PRIM-100

Ref. SE-STRIB CAB 45 V

Manufacturer of **ANTIVIBRATION** systems

Chart 2

ACOUSTIC / HYBRID Ceiling

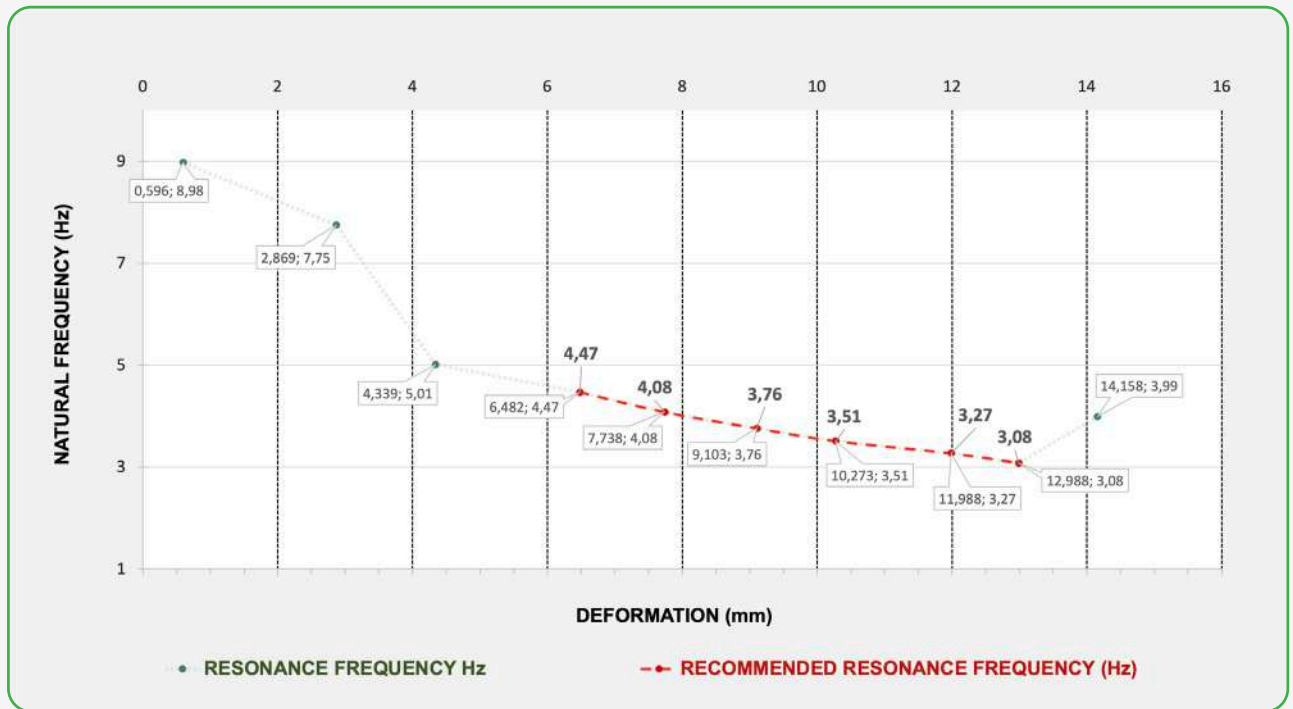

Ref.
STRIB CAB 45 V

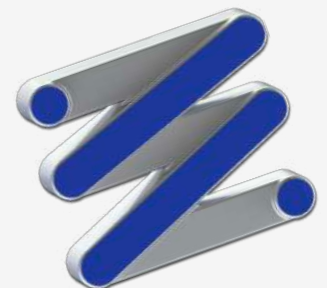

*SENOR Aisladores Acústicos



CONSTRUCTION Catalogue 2021

HYBRID HANGER WITH DIRECT FASTENING TO PROFILE STIL PRIM-100

Ref. SE-STRIB CAB 45 V

Chart 3

ACOUSTIC / HYBRID Ceiling



Ref.
STRIB CAB 45 V

CONSTRUCTION Catalogue 2021

HYBRID HANGER WITH DIRECT FASTENING TO PROFILE STIL PRIM-100

Ref. SE-STRIB CAB 45 V

DRAWING VIEWS

Manufacturer of **ANTIVIBRATION** systems

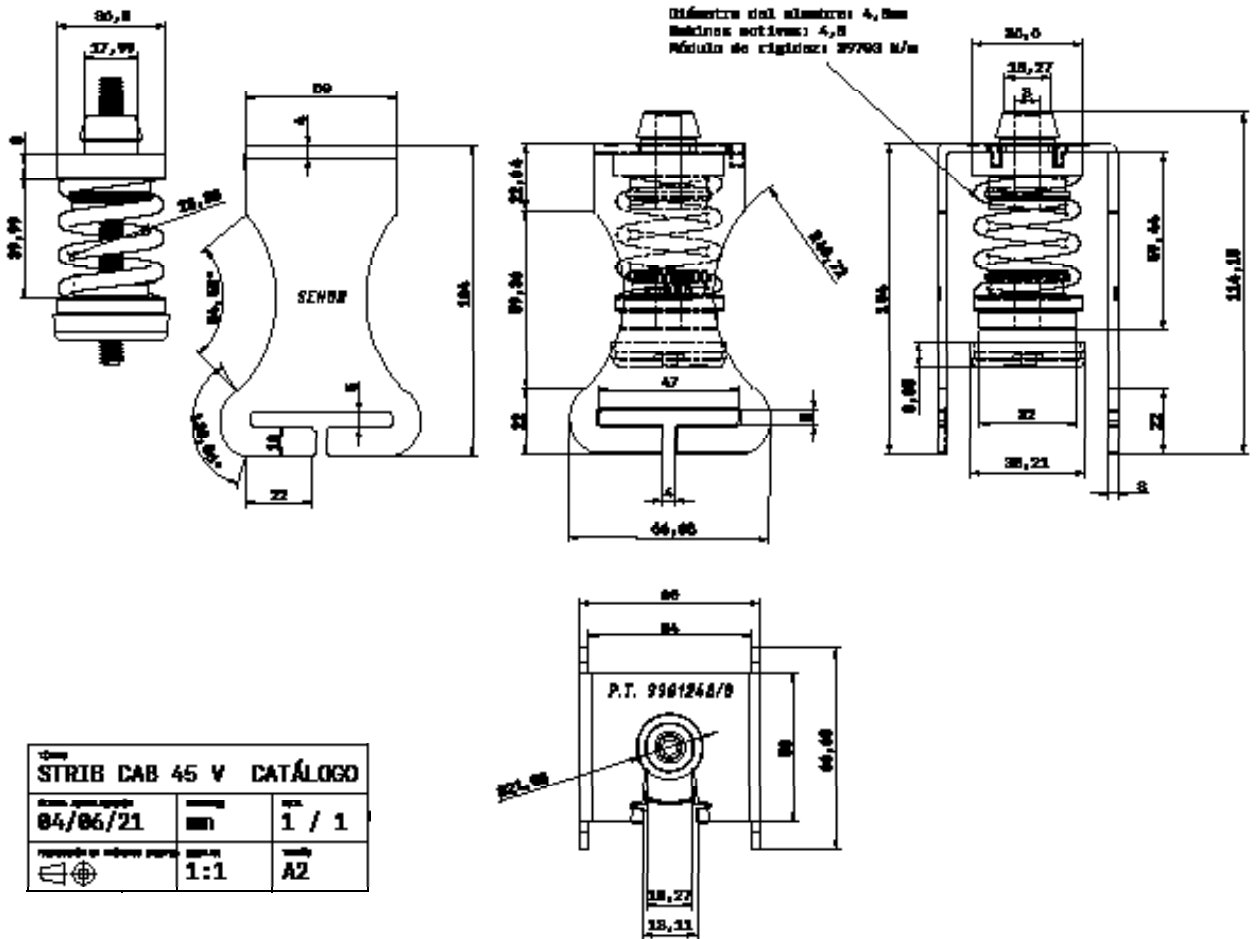

SE-STRIB CAB 45 V CATÁLOGO		
Identificación del producto	mm	1 / 1
Referencia de montaje	1:1	A2



*SEÑOR Aisladores Acústicos



CONSTRUCTION Catalogue 2021

HYBRID HANGER WITH DIRECT FASTENING TO PROFILE STIL PRIM-100

Ref. SE-STRIB CAB 45 V

N° PT

U. 009901248

Mechanical test **LABORATORY**

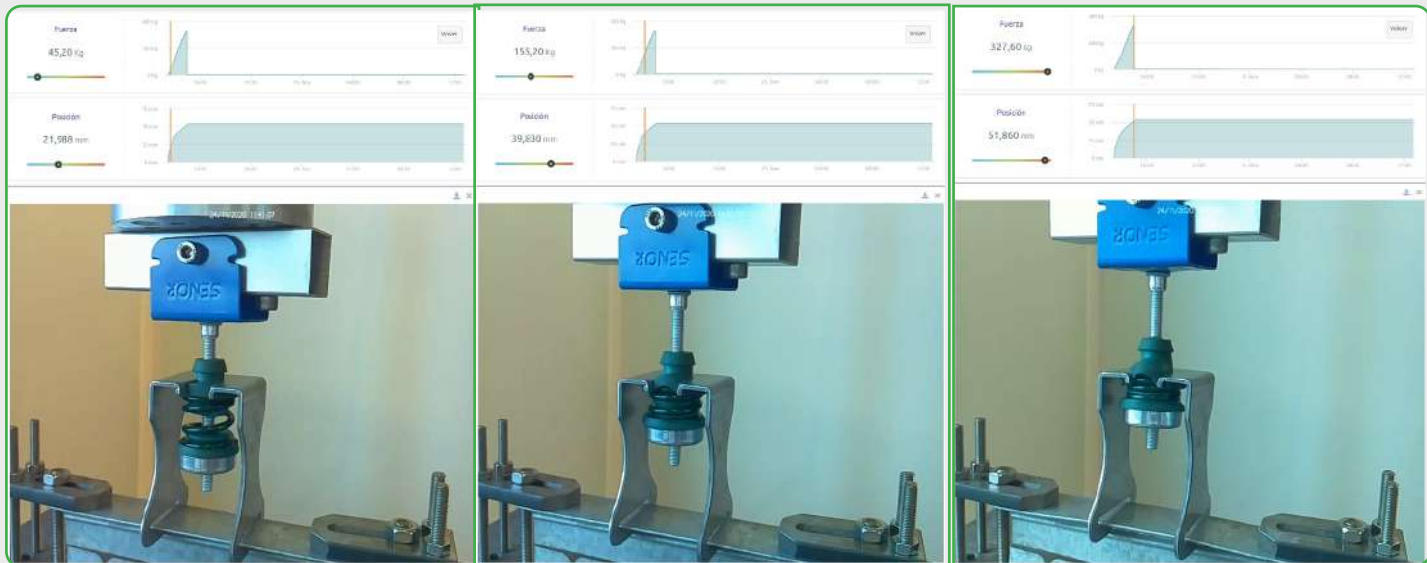

Test layout: 45 kg

Test layout: 155 kg

Test layout: 327 kg

STRIB CAB 45 V

STRIB CAB 45 V

STRIB CAB 45 V

In this test, the hanger is subjected to load within the parameters designed to the product.

In this test, the hanger is subjected to load out of the parameters designed to the product.

We can see steel spring and polymers very compressed.

Failure mode. It is produced tearing in the thread shaped part of the bowl shaped.

CONSTRUCTION Catalogue 2021

HYBRID HANGER WITH DIRECT FASTENING TO PROFILE STIL PRIM-100

Ref. SE-STRIB CAB 45 V

STRIB CAB 45 V

Failure mode.

When the bowl shaped leveller reaches **327 kg** is broken in its thread shaped part and it is detached. The burst test is concluded.

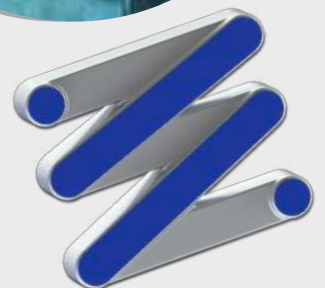

Manufacturer of **ANTIVIBRATION** systems



*SENOR Aisladores Acústicos



CONSTRUCTION Catalogue 2021

HYBRID HANGER WITH DIRECT FASTENING TO PROFILE STIL PRIM-100

Ref. SE-STRIB CAB 45 V

Nº PT

U. 009901248

Certificate of COMPLIANCE



SENOR certifies:

The **Mod.STRIB CAB** in the **construction** range for the suspension of low acoustic false ceilings under slab has an optimal lifespan of **10 years** provided that the installation is carried out under **ordinary environmental** conditions and are not exposed to chemical components that could degrade the product. The model **Mod.STRIB CAB** series strictly complies with UNE (Spanish Association for Standardization) **UNE 100-153-88**: air conditioning; vibration insulators: design criteria.

SENOR declares under his responsibility that the following components for suspended ceiling in buildings strictly complies with the technical sections of installation mentioned in the technical documentation of the product.



Certificación
Concedida a
SUSPENSIONES ELASTICAS DEL NORTE SL

PLG. IND. EL GARROTAL, PARCELA 10 MÓDULO 5 - 14700 - PALMA DEL RIO - CÓRDOBA. - ESPAÑA

Bureau Veritas Certification certifica que el Sistema de Gestión ha sido auditado y encontrado conforme con los requisitos de la norma:

NORMA

ISO 9001:2015



El Sistema de Gestión se aplica a:

DISEÑO, DESARROLLO Y FABRICACIÓN DE AISLADORES ACÚSTICOS PARA LA ERRADICACIÓN DE LAS VIBRACIONES Y LA CONTAMINACIÓN POR RUIDO PARA SU APLICACIÓN EN LOS SECTORES DE LA CONSTRUCCIÓN Y LA INDUSTRIA.

Número del Certificado:	ES114742-1
Aprobación original:	25-09-2002
Auditoría de certificación/renovación:	14-09-2020
Expiración de ciclo anterior:	03-10-2020
Certificado en vigor:	04-10-2020
Expiración del certificado:	03-10-2023

Este certificado está sujeto a los términos y condiciones generales y particulares de los servicios de certificación

Bureau Veritas Iberia S.L.
C/ Valparaíso Primera 22-24, Edificio Casha, 28906 Alcobendas - Madrid, España

171

CONSTRUCTION Catalogue 2021

HYBRID HANGER WITH DIRECT FASTENING TO PROFILE STIL PRIM-100

Ref. SE-STRIB CAB 45 V

N° PT

U. 009901248

Warning

Relevant information

SENOR reserves the right to make changes in specifications at any time without prior notice. It is a responsibility of the user to use the latest and updated version of the product data sheets. **A copy of which will be available on request.** This information and, in particular, relative recommendations to the application and final use of the product, are given in good faith, based on **SENOR** knowledge and experience of its products, provided that they are correctly installed in ordinary circumstances and within its useful life.

Manufacturer of **ANTIVIBRATION** systems

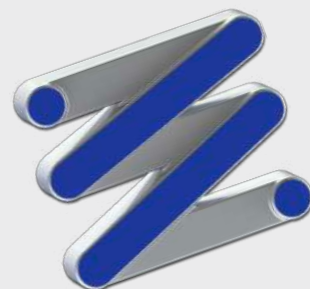

CONSTRUCTION Catalogue

2021

**HYBRID HANGER WITH
DIRECT FASTENING TO PROFILE
STIL PRIM-100**

Ref. SE-STRIB CAB 75 A



SENIOR

CONSTRUCTION Catalogue 2021

HYBRID HANGER WITH DIRECT FASTENING TO PROFILE STIL PRIM-100

Ref. SE-STRIB CAB 75 A

Introduction

A **DIFFERENT** and **PROFESSIONAL** hanger. Higher performance in the least space. They are **HYBRID** hangers with locking stops named **CUG**. Our engineers work every day for your safety.

STRIB CAB 75 A is manufactured with high performance and renovated raw material providing improvements in the vibro-acoustic field.

STRIB CAB 75 A is more than a hanger. It is an acoustic hanger with fast adjustment to first profile **STIL PRIM 100**. The profile is fixed with a simple gesture making him an **innovative and unique product**.

We use the latest technology in the production such as: renovated polymers (**KRAIBURG-TPE**) tested according to **UNE-EN ISO 10846-1:2009** and placed in the sides on the steel spiral. The steel spring is manufactured according to **DIN 2095 UNE EN 10270**, with **BLUE EPOXY** treatment.

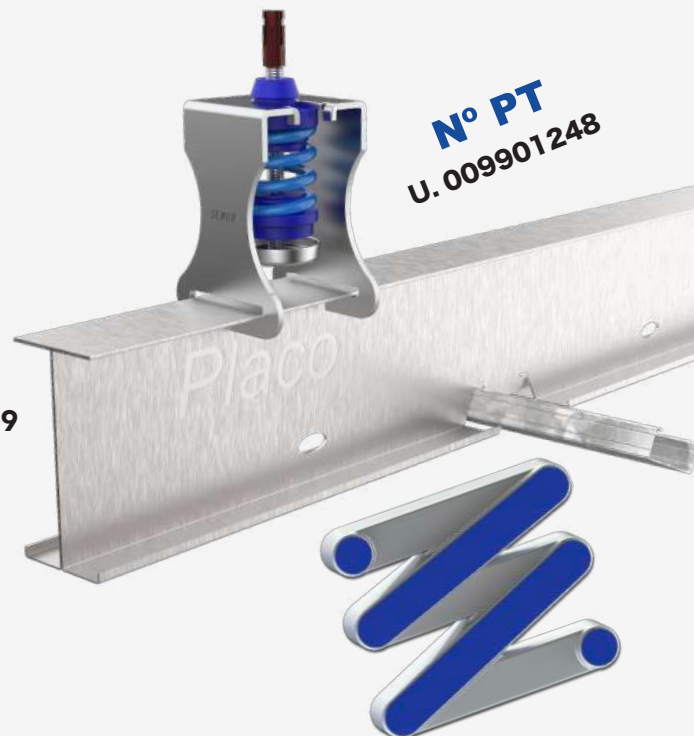

Manufacturer of **ANTIVIBRATION** systems



*SENROR Aisladores Acústicos



CONSTRUCTION Catalogue 2021

HYBRID HANGER WITH DIRECT FASTENING TO PROFILE STIL PRIM-100

Ref. SE-STIRIB CAB 75 A

N° PT

U. 009901248

ACOUSTIC / HYBRIDE Ceiling

STEEL SPRING: it provides a high level of insulation to vibrations in the range of low/medium frequencies (Hz).

RENOVATED POLYMERS: they have a better damping factor and a higher degree of insulation to vibration in the range of **medium/high** frequencies (Hz).

COMBINATION: the combination makes possible launch onto the market the best hanger of the moment and reduce the vibrations in the range of exciter frequencies.

It is available in several metrics: 6, 8 and 10.

LOAD RANGE (KG)

It is recommended to loads between **30 kg** and **75 kg** of maximum load.

(Strongly recommended not to exceed this limit in order to prevent overstressing the polymer).

RESONANCE frequency: 3-7 Hz.

CONSTRUCTION Catalogue

2021

Nº PT

U. 009901248

HYBRID HANGER WITH DIRECT FASTENING TO PROFILE STIL PRIM-100

Ref. SE-STRIB CAB 75 A

LABORATORY Test. UNE-EN ISO 10846-1:2009

Acoustic and vibration. Measurement in the laboratory of vibro-acoustic transfer properties of elastic elements.

Manufacturer of **ANTIVIBRATION** systems

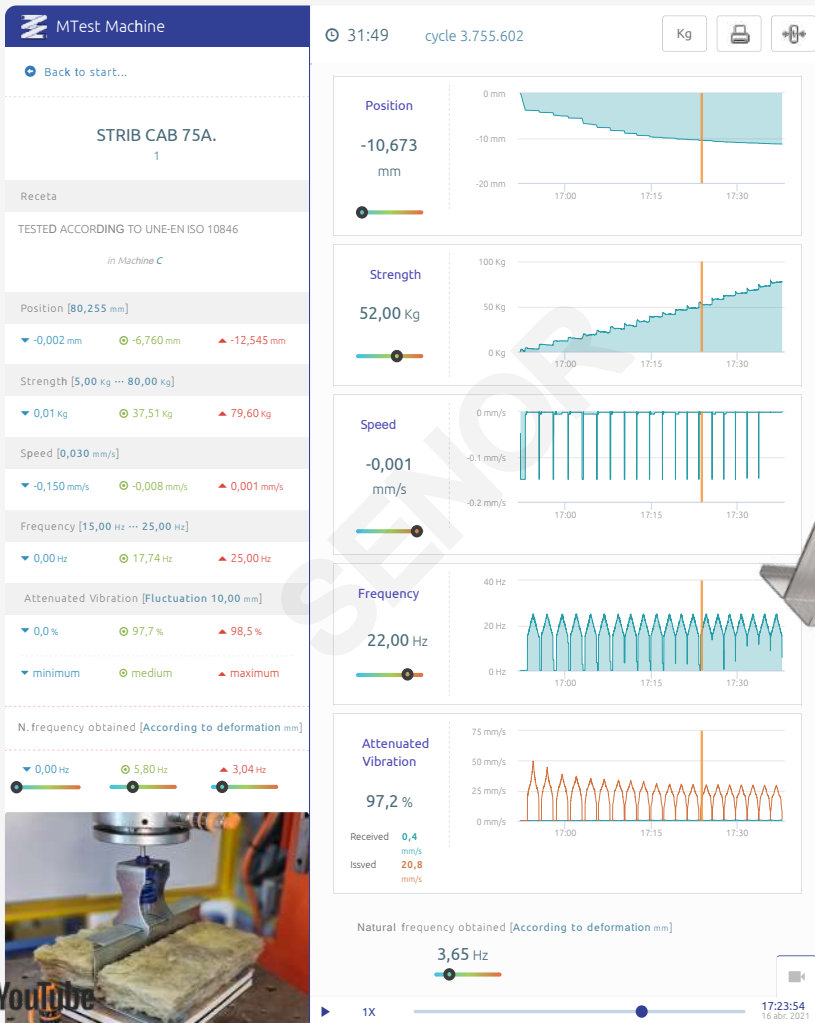

(D¹)

Internal **Axial**
Compression

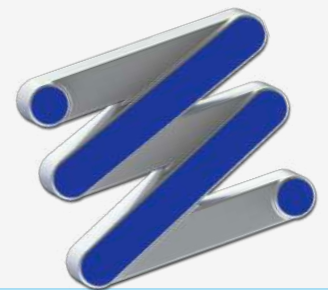
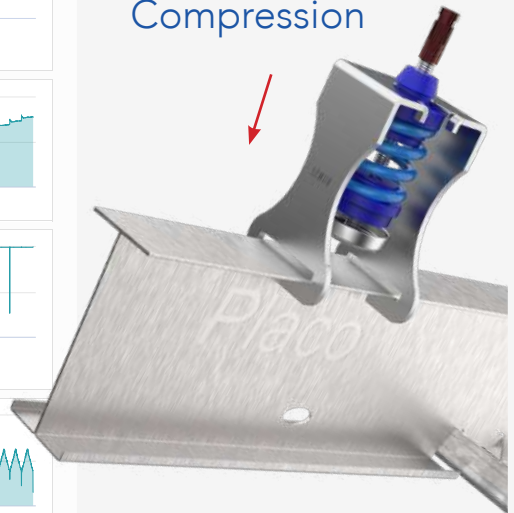

*SENOR Aisladores Acústicos



CONSTRUCTION Catalogue 2021

HYBRID HANGER WITH DIRECT FASTENING TO PROFILE STIL PRIM-100

Ref. SE-STRIB CAB 75 A

LABORATORY RESULTS

Chart 1

ACOUSTIC / HYBRID Ceiling



N° PT
U. 009901248

BLUE: RUBBER & SPRING
Available references

- 1°- SE-STRIB CAB 75 A/M6.
- 2°- **SE-STRIB CAB 75 A/M8.**
- 3°- SE-STRIB CAB 75 A/M10.

CONSTRUCTION Catalogue 2021

HYBRID HANGER WITH DIRECT FASTENING TO PROFILE STIL PRIM-100

Ref. SE-STRIB CAB 75 A

Manufacturer of **ANTIVIBRATION** systems

Chart 2

ACOUSTIC / HYBRID Ceiling

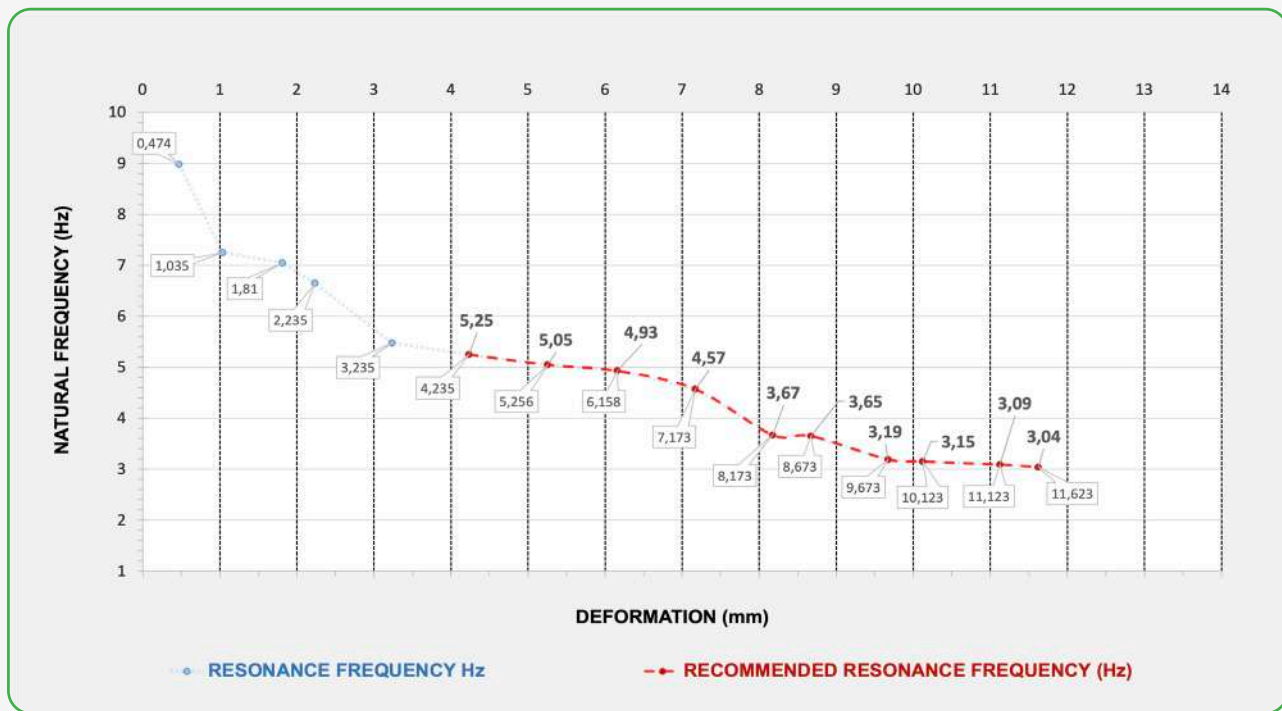

Ref.
STRIB CAB 75 A



*SENOR Aisladores Acústicos



CONSTRUCTION Catalogue 2021

HYBRID HANGER WITH DIRECT FASTENING TO PROFILE STIL PRIM-100 Ref. SE-STRIB CAB 75 A

Chart 3

ACOUSTIC / HYBRID Ceiling



Ref.
STRIB CAB 75 A

CONSTRUCTION Catalogue 2021

HYBRID HANGER WITH DIRECT FASTENING DIRECT TO PROFILE STIL PRIM-100

Ref. SE-STRIB CAB 75 A

DRAWING VIEWS

Manufacturer of **ANTIVIBRATION** systems

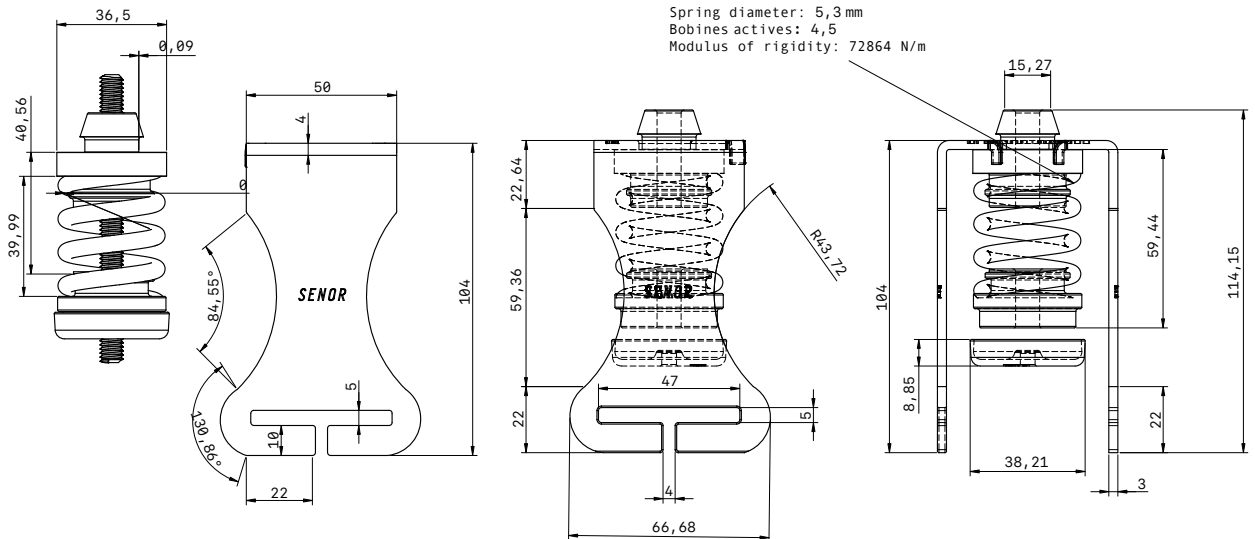

N° PT
U. 009901248

TÍTULO STRIB CAB 75 A CATÁLOGO		
ÚLTIMA ACTUALIZACIÓN 04/22/21	UNIDADES mm	Hoja 1 / 1
PROYECCIÓN EN DIÉDRICO EUROPEO	ESCALAR 1:1	TAMAÑO A2

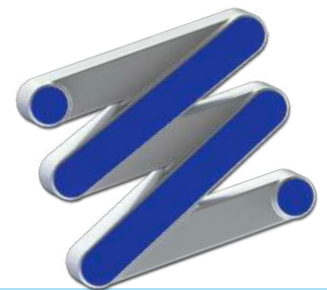
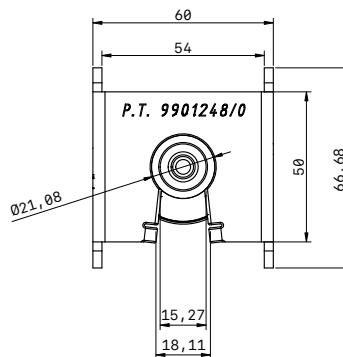

*SENOR Aisladores Acústicos



CONSTRUCTION Catalogue 2021

HYBRID HANGER WITH DIRECT FASTENING TO PROFILE STIL PRIM-100

N° PT

U. 009901248

Ref. SE-STRIB CAB 75 A

Mechanical test **LABORATORY**

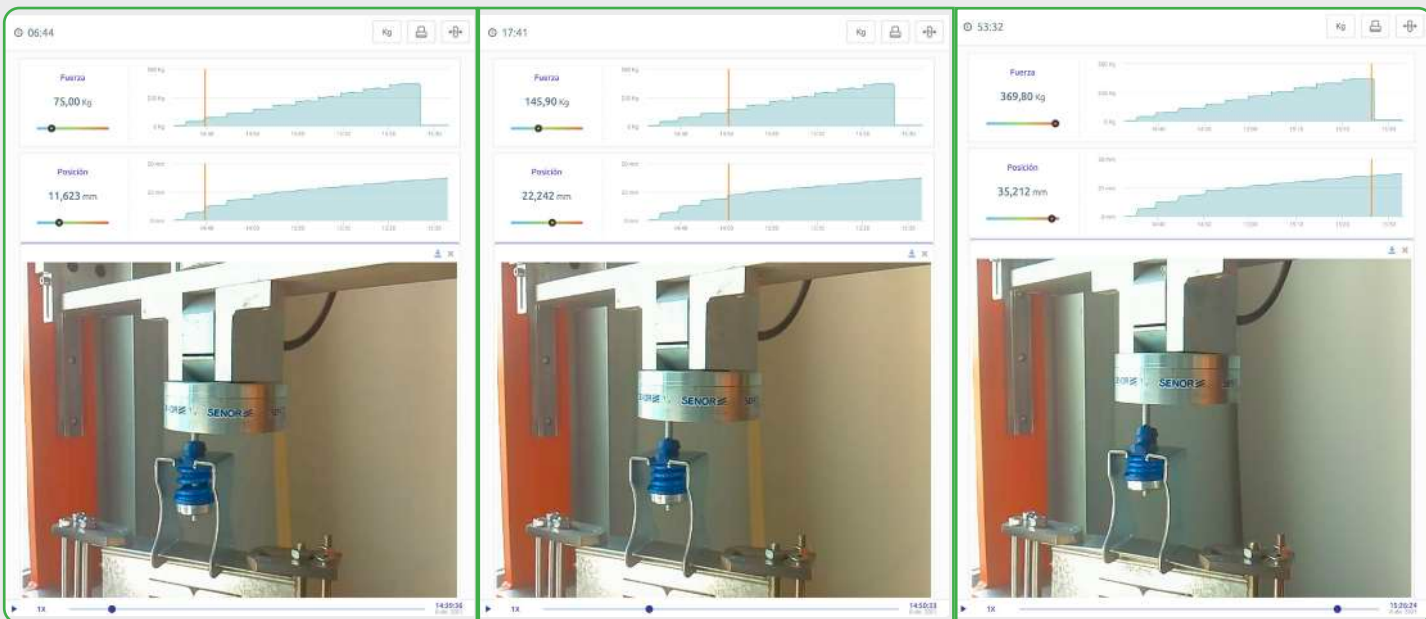

Test layout: 75 kg

STRIB CAB 75 A

In this test, the hanger is subjected to load inside the parameters designed to the product.

Test layout: 145 kg

STRIB CAB 75 A

In this test, the hanger is subjected to load out of the parameters designed to the product.
We can see steel spring and polymers very compressed.

Test layout: 369 kg

STRIB CAB 75 A

Failure mode.
It is produced tearing in the thread shaped part of the bowl shaped.

CONSTRUCTION Catalogue 2021

HYBRID HANGER WITH DIRECT FASTENING TO PROFILE STIL PRIM-100

Ref. SE-STRIB CAB 75 A

Manufacturer of **ANTIVIBRATION** systems



STRIB CAB 75 A

Failure mode.

When the bowl shaped leveller reaches **369 kg** is broken in its thread shaped part and it is detached. The burst test is concluded.

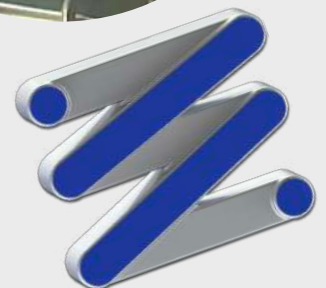

*SENOR Aisladores Acústicos

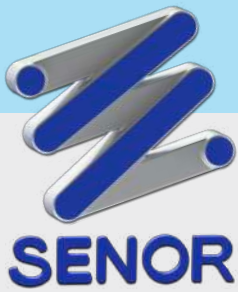

CONSTRUCTION Catalogue 2021

HYBRID HANGER WITH DIRECT FASTENING TO PROFILE STIL PRIM-100

Ref. SE-STRIB CAB 75 A

N° PT

U. 009901248

Certificate of COMPLIANCE



SENOR certifies:

The **Mod.STRIB CAB** in the **construction** range for the suspension of low acoustic false ceilings under slab has an optimal lifespan of **10 years** provided that the installation is carried out under **ordinary environmental** conditions and are not exposed to chemical components that could degrade the product. The **Mod.STRIB CAB** series strictly complies with **UNE** (Spanish Association for Standardization) **UNE 100-153-88**: air conditioning: vibration insulators: design criteria.

SENOR declares under its responsibility that the following components for suspended ceiling in buildings strictly complies with the technical sections of installation mentioned in the technical documentation of the product.

Certificación
Concedida a
SUSPENSIONES ELASTICAS DEL NORTE SL

PLG. IND. EL GARROTAL, PARCELA 10 MODULO 5 - 14700 - PALMA DEL RIO - CORDOBA. - ESPAÑA

Bureau Veritas Certification certifica que el Sistema de Gestión ha sido auditado y encontrado conforme con los requisitos de la norma:

NORMA
ISO 9001:2015

El Sistema de Gestión se aplica a:

DISEÑO, DESARROLLO Y FABRICACIÓN DE AISLADORES ACÚSTICOS PARA LA ERRADICACIÓN DE LAS VIBRACIONES Y LA CONTAMINACIÓN POR RUIDO PARA SU APLICACIÓN EN LOS SECTORES DE LA CONSTRUCCIÓN Y LA INDUSTRIA.

Número del Certificado:	ES114742- 1
Aprobación original:	25-09-2002
Auditoría de certificación/renovación:	14-09-2020
Caducidad de ciclo anterior:	03-10-2020
Certificado en vigor:	04-10-2020
Caducidad del certificado:	03-10-2023

Este certificado está sujeto a los términos y condiciones generales y particulares de los servicios de certificación

Bureau Veritas Iberia S.L.
C/ Valportillo Primera 22-24, Edificio Caoba, 28108 Alcobendas - Madrid, España

1/1

CONSTRUCTION Catalogue 2021

HYBRID HANGER WITH DIRECT FASTENING TO PROFILE STIL PRIM-100

Ref. SE-STRIB CAB 75 A

Warning

Relevant information

N° PT

U. 009901248

SE reserves the right to make changes in specifications at any time without prior notice. It is a responsibility of the user to use the latest and updated version of the product data sheets. A copy of which will be available on request. This information and, in particular, relative recommendations to the application and final use of the product, are given in good faith, based on **SE** knowledge and experience of its products, provided that they are correctly installed in ordinary circumstances and within its useful life.

Manufacturer of **ANTIVIBRATION** systems



*SE Aisladores Acústicos

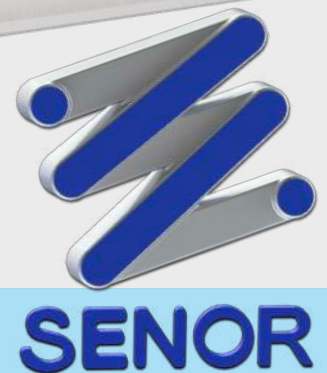

CONSTRUCTION Catalogue

2021

HYBRID HANGER WITH
DIRECT FASTENING TO
PROFILE **STIL PRIM-100**



Ref. SE-STRIB CAB 120 R

SENIOR

CONSTRUCTION Catalogue 2021

HYBRID HANGER WITH DIRECT FASTENING TO PROFILE **STIL PRIM-100**

Ref. **SE-STRIB CAB 120 R**

Introduction

A **DIFFERENT** and **PROFESSIONAL** hanger. Higher performance in the least space. They are **HYBRID** hangers with locking stops named **CUG**. Our engineers work every day for your safety.

STRIB CAB 120 R is made of high performance and renovated raw material providing improvements in the **vibro-acoustic** field.



STRIB CAB 120 R is more than a hanger. It is an acoustic hanger with fast adjustment to first profile **STIL PRIM 100**. The profile is fixed with a simple gesture making him an **innovative** and **unique** product.

We use the latest technology in the production such as: renovated polymers (**KRAIBURG-TPE**) tested according to **UNE-EN ISO 10846-1:2009** and placed in the sides on the steel spiral.

The steel spring is manufactured according to **DIN 2095 UNE EN 10270**, with **RED EPOXY** treatment.



Nº PT
U. 009901248

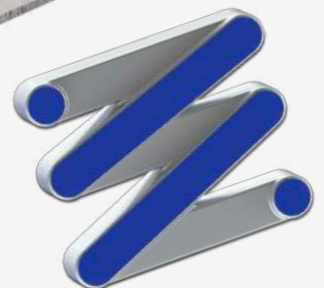

Manufacturer of **ANTIVIBRATION** systems



*SENROR Aisladores Acústicos

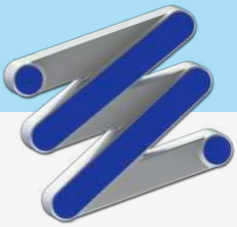

SENROR
N° PT

U. 009901248

CONSTRUCTION Catalogue 2021

**HYBRID HANGER WITH
DIRECT FASTENING TO
PROFILE STIL PRIM-100**

Ref. SE-STRIB CAB 120 R

ACOUSTIC / HYBRIDE Ceiling

STEEL SPRING: it provides a high level of insulation to **vibrations** in the range of **low/medium** frequencies (Hz).

RENOVATED POLYMERS: they have a better damping factor and a higher degree of insulation to vibration in the range of **medium/high** frequencies (Hz).

COMBINATION: the combination makes possible launch onto the market the best hanger of the moment and reduce the **vibrations** in the range of **exciter** frequencies.

It is available in several metrics: 6, 8 and 10.

LOAD RANGE (kg)

It is recommended to loads between **60 kg** and **120 kg** of maximum load.

(Strongly recommended not to exceed this limit in order to prevent overstressing the polymer).

RESONANCE frequency: **3-7 Hz**.

CONSTRUCTION Catalogue 2021

HYBRID HANGER WITH DIRECT FASTENING TO PROFILE **STIL PRIM-100**

Ref. **SE-STRIB CAB 120 R**

LABORATORY Test. UNE-EN ISO 10846-1:2009

Acoustic and vibration. Measurement in the laboratory of vibro-acoustic transfer properties of elastic elements.

Manufacturer of **ANTIVIBRATION** systems

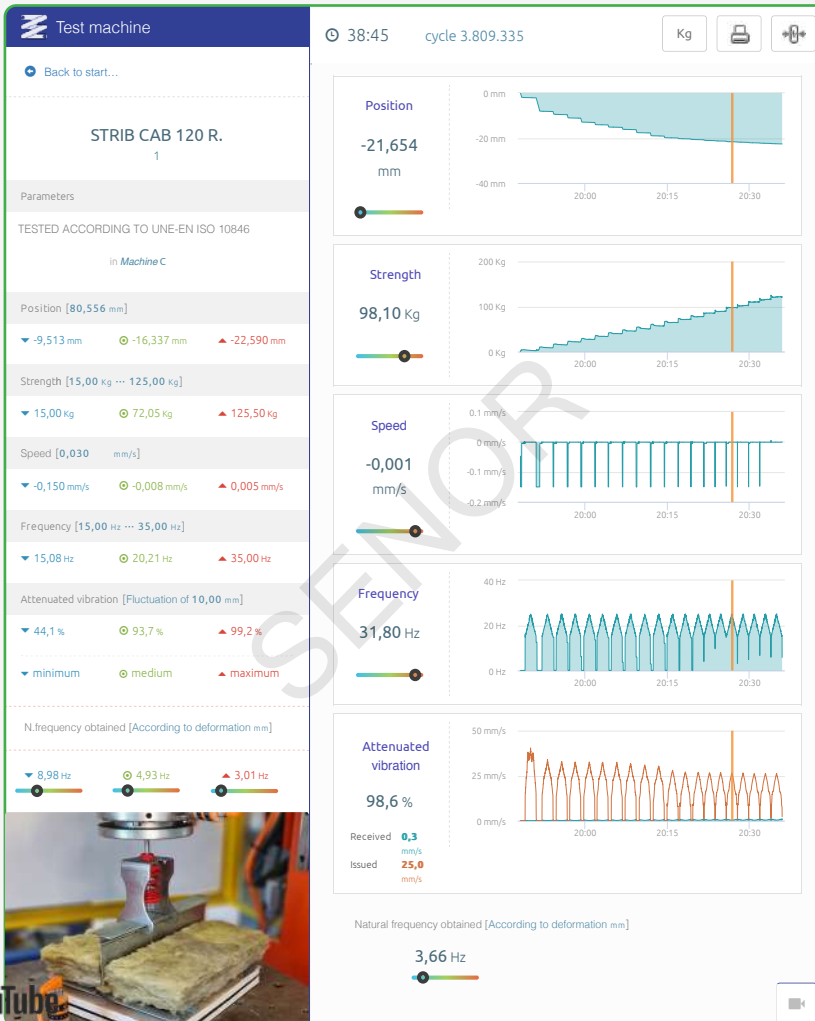

(D¹)

Internal **Axial**
Compression



N° PT
U. 009901248

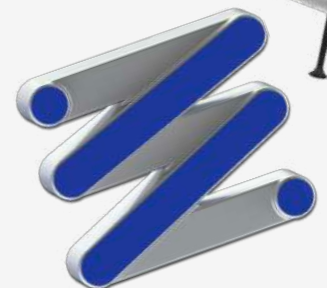



CONSTRUCTION Catalogue 2021

HYBRID HANGER WITH DIRECT FASTENING TO PROFILE **STIL PRIM-100**

Ref. SE-STRIB CAB 120 R

LABORATORY RESULTS

Chart 1

ACOUSTIC / HYBRID Ceiling

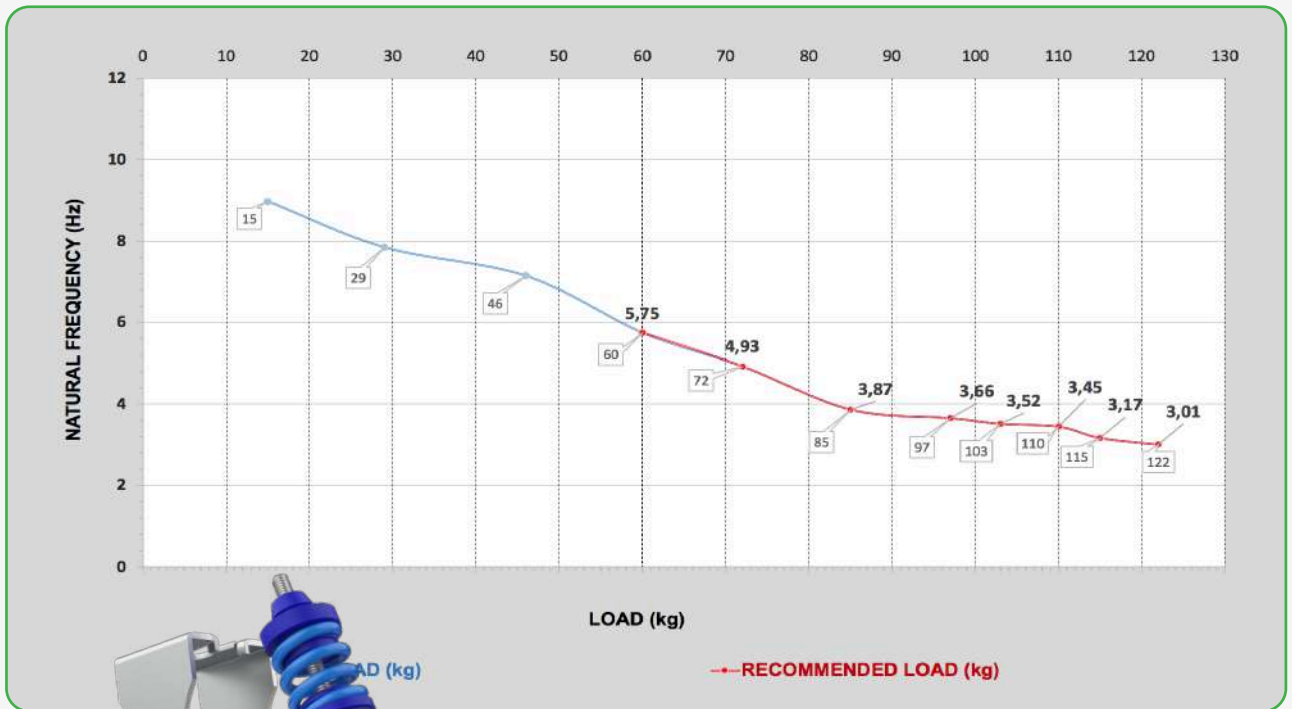

N° PT
U. 009901248

RED RUBBER & SPRING:
Available references

- 1° SE-STRIB CAB 120 R/M6.
- 2° SE-STRIB CAB 120 R/M8.**
- 3° SE-STRIB CAB 120 R/M10.

CONSTRUCTION Catalogue 2021

HYBRID HANGER WITH DIRECT FASTENING TO PROFILE **STIL PRIM-100**

Ref. SE-STRIB CAB 120 R

Manufacturer of **ANTIVIBRATION** systems

Chart 2

ACOUSTIC / HYBRID Ceiling

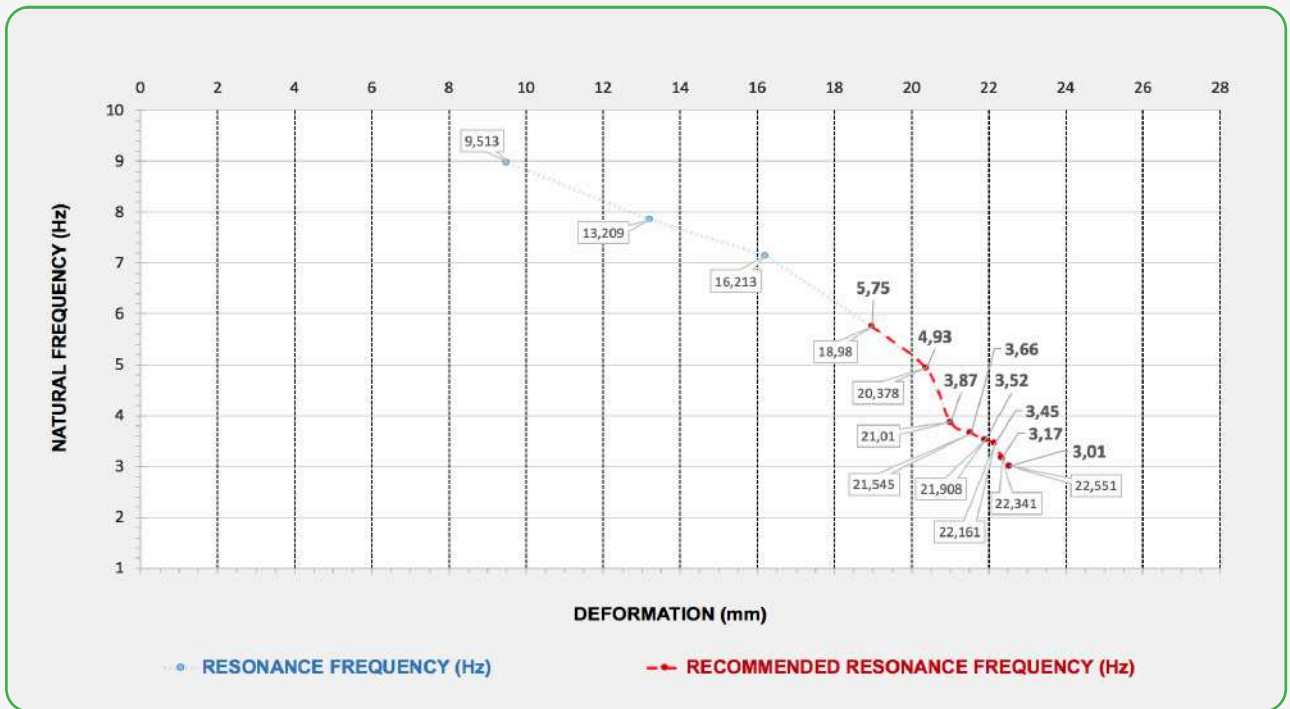

Ref.
STRIB CAB 120 R

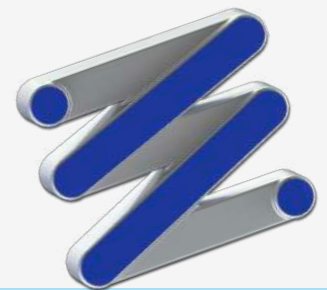

*SENOR Aisladores Acústicos



CONSTRUCTION Catalogue 2021

**HYBRID HANGER WITH
DIRECT FASTENING TO
PROFILE STIL PRIM-100**

Ref. SE-STRIB CAB 120 R

LABORATORY RESULTS

Chart 3

ACOUSTIC / HYBRID Ceiling

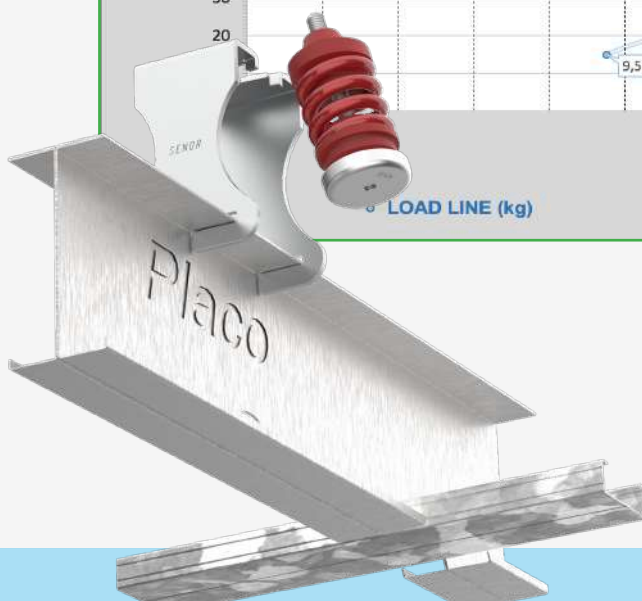
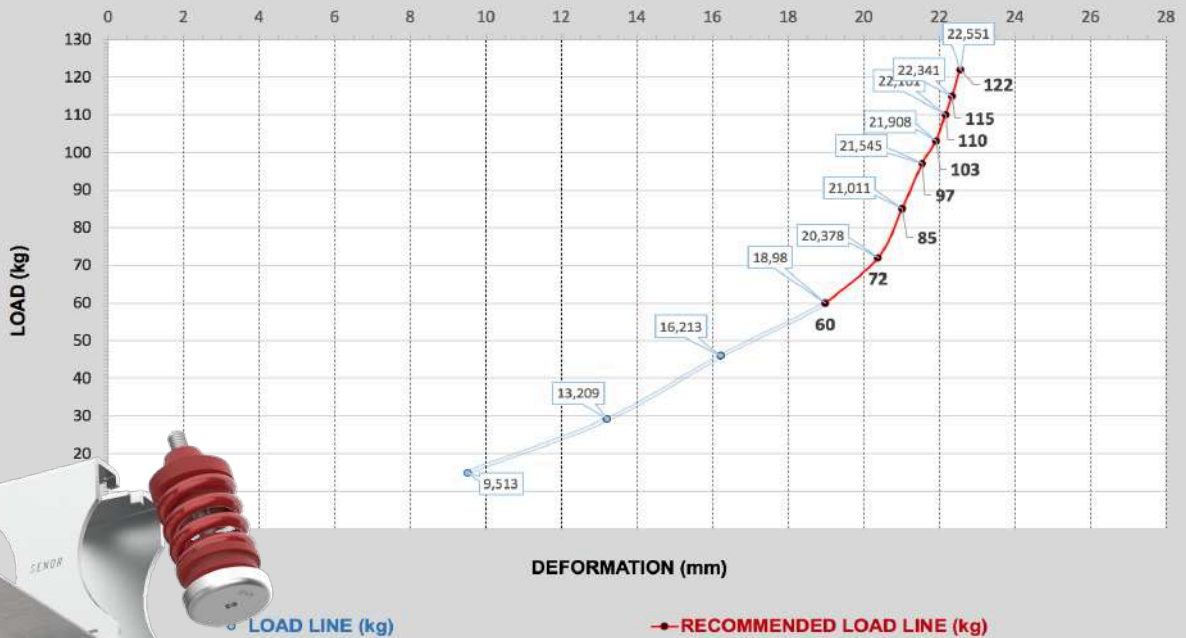

**Ref.
STRIB CAB 120 R**

CONSTRUCTION Catalogue 2021

HYBRID HANGER WITH DIRECT FASTENING TO PROFILE **STIL PRIM-100**

Ref. **SE-STRIB CAB 120 R**

DRAWING VIEWS

Manufacturer of **ANTIVIBRATION** systems

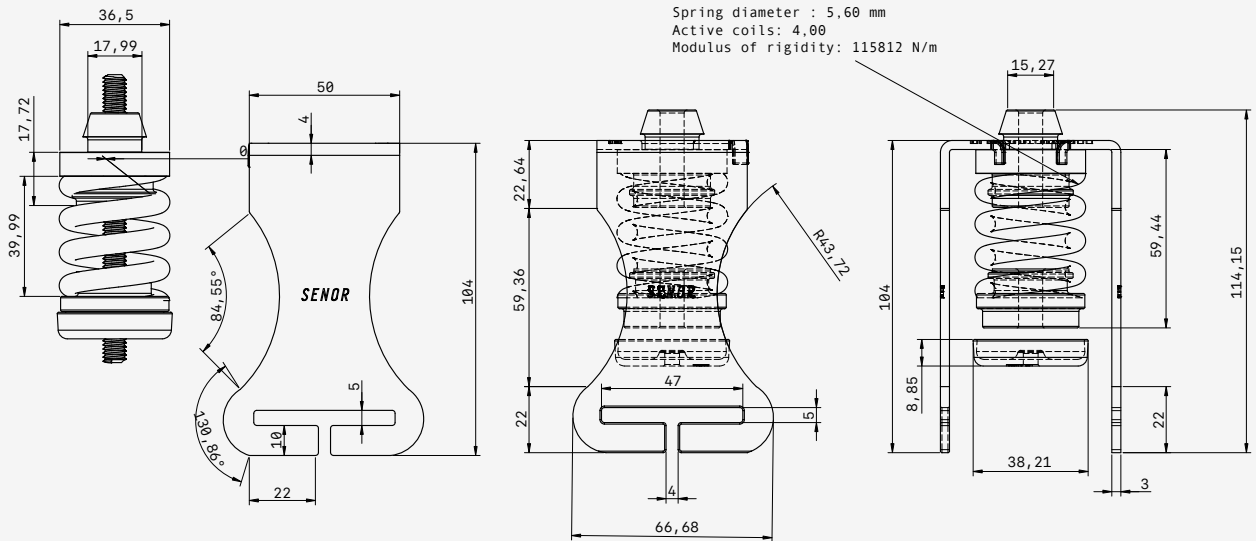

N° PT
U. 009901248

TÍTULO STRIB CAB 120 R		
ÚLTIMA ACTUALIZACIÓN 05/11/21	UNIDADES mm	HOJA 1 / 1
PROYECCIÓN EN DIÉDRICO EUROPEO	ESCALAR 1:1	TAMAÑO A2

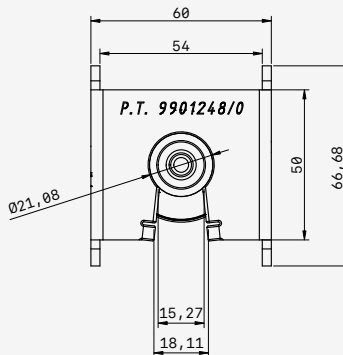

*SENOR Aisladores Acústicos

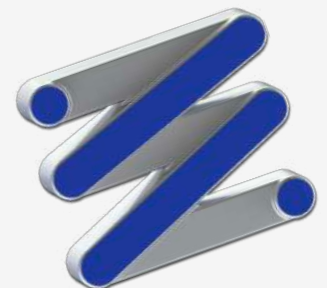

SENOR



CONSTRUCTION Catalogue 2021

**HYBRID HANGER WITH
DIRECT FASTENING TO
PROFILE STIL PRIM-100**

**N° PT
U. 009901248**

Ref. SE-STRIB CAB 120 R

LABORATORY Mechanical test



Test layout: 120 kg

STRIB CAB 120 R

In this test, the hanger is subjected to load within the parameters designed to the product.

Test layout: 247 kg

STRIB CAB 120 R

In this test, the hanger is subjected to load out of the parameters designed to the product.
We can see steel spring and polymers very compressed.

Test layout: 377 kg

STRIB CAB 120 R

Failure mode.
It is produced tearing in the thread shaped part of the bowl shaped.

**Ref.
STRIB CAB 120 R**

CONSTRUCTION Catalogue 2021

HYBRID HANGER WITH DIRECT FASTENING TO PROFILE **STIL PRIM-100**

Ref. **SE-STRIB CAB 120 R**

STRIB CAB 120 R

Failure mode.

When the bowl shaped leveller reaches **377 kg** is broken in its thread shaped part and it is detached. The burst test is concluded.

Manufacturer of **ANTIVIBRATION** systems

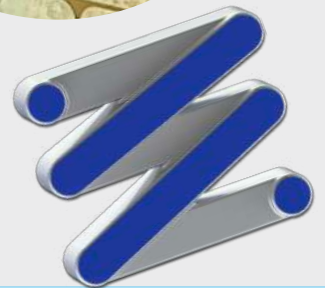

*SENOR Aisladores Acústicos



CONSTRUCTION Catalogue 2021

**HYBRID HANGER WITH
DIRECT FASTENING TO
PROFILE STIL PRIM-100**

Ref. SE-STRIB CAB 120 R

**Nº PT
U. 009901248**

Certificate of COMPLIANCE



SEÑOR certifies:

The **Mod.STRIB CAB** in the construction range for the suspension of low acoustic false ceilings under slab has an optimal lifespan of **10 years** provided that the installation is carried out under ordinary environmental conditions and are not exposed to chemical components that could degrade the product. The **Mod.STRIB CAB** series strictly complies with **UNE** (Spanish Association for Standardization) **UNE 100-153-88**: air conditioning: vibration insulators: design criteria.

SEÑOR declares under its responsibility that the following components for suspended ceiling in buildings strictly complies with the technical sections of installation mentioned in the technical documentation of the product.

Certificación
Concedida a
SUSPENSIONES ELASTICAS DEL NORTE SL

PLG. IND. EL GARROTAL, PARCELA 10 MODULO 5 - 14700 - PALMA DEL RIO - CÓRDOBA. - ESPAÑA

Bureau Veritas Certification certifica que el Sistema de Gestión ha sido auditado y encontrado conforme con los requisitos de la norma:

NORMA
ISO 9001:2015

El Sistema de Gestión se aplica a:

DISEÑO, DESARROLLO Y FABRICACIÓN DE AISLADORES ACÚSTICOS PARA LA ERRADICACIÓN DE LAS VIBRACIONES Y LA CONTAMINACIÓN POR RUIDO PARA SU APLICACIÓN EN LOS SECTORES DE LA CONSTRUCCIÓN Y LA INDUSTRIA.

Número del Certificado:	ES114742- 1
Aprobación original:	25-09-2002
Auditoría de certificación/renovación:	14-09-2020
Caducidad de ciclo anterior:	03-10-2020
Certificado en vigor:	04-10-2020
Caducidad del certificado:	03-10-2023

Este certificado está sujeto a los términos y condiciones generales y particulares de los servicios de certificación

Bureau Veritas Iberia S.L.
C/ Valportillo Primera 22-24, Edificio Caoba, 28108 Alcobendas - Madrid, España

1/1

CONSTRUCTION Catalogue

2021

HYBRID HANGER WITH DIRECT FASTENING TO PROFILE **STIL PRIM-100**

Ref. SE-STRIB CAB 120 R

Warning

Relevant information

SENIOR reserves the right to make changes in specifications at any time without prior notice. It is a responsibility of the user to use the latest and updated version of the product data sheets. A copy of which will be available on request. This information and, in particular, relative recommendations to the application and final use of the product, are given in good faith, based on **SENIOR** knowledge and experience of its products, provided that they are correctly installed in ordinary circumstances and within its useful life.



N° PT
U. 009901248

Manufacturer of **ANTIVIBRATION** systems



*SENIOR Aisladores Acústicos

