

SENOR

ACOUSTIC wall cladding

Mod. FTD OMEGA



A shock absorber designed for
ACOUSTIC WALL PANELS.

Mod.
FTD OMEGA

ISO 9001:2015



Ref.
FTD OMEGA

ACOUSTIC Cladding

Mod. FTD OMEGA

The thinnest shock absorber for tight spaces.

FTD/OMEGA is a unique isolator that stands out for its simplicity. It allows isolating and separating wall and acoustic ceiling panels using **OMEGA**-type metal profiles for gypsum boards. It is capable, on its own, of reducing space to a minimum with incredible results **already tested**". It is designed to eradicate and attenuate the transmission of vibrations produced by **shocks, impacts** o **vibromechanical energies** from equipment that generates acoustic pollution above the threshold of the audible field (20 Hz).

*SENOR acoustic insulators.



Introduction **Mod. FTD OMEGA**

A different shock absorber with constant EVOLUTION for acoustic lining in confined spaces.

SENOR has made it possible by applying the latest technologies in the sector. "Vibro-acoustics"

They are first generation shock absorbers with double wall attachment. They are **made up of:**

Double acoustic core, manufactured using a renewed **polymer**, providing greater performance to the shock absorber.



The "TC 4 / GPN" presents a higher damping factor and a high degree of acoustic isolation to vibrations in the range of low, medium and high frequencies Hz. Providing improvements in its internal mechanical properties and an increase >10% in the soundproofing performance.



Ref.
FTD OMEGA

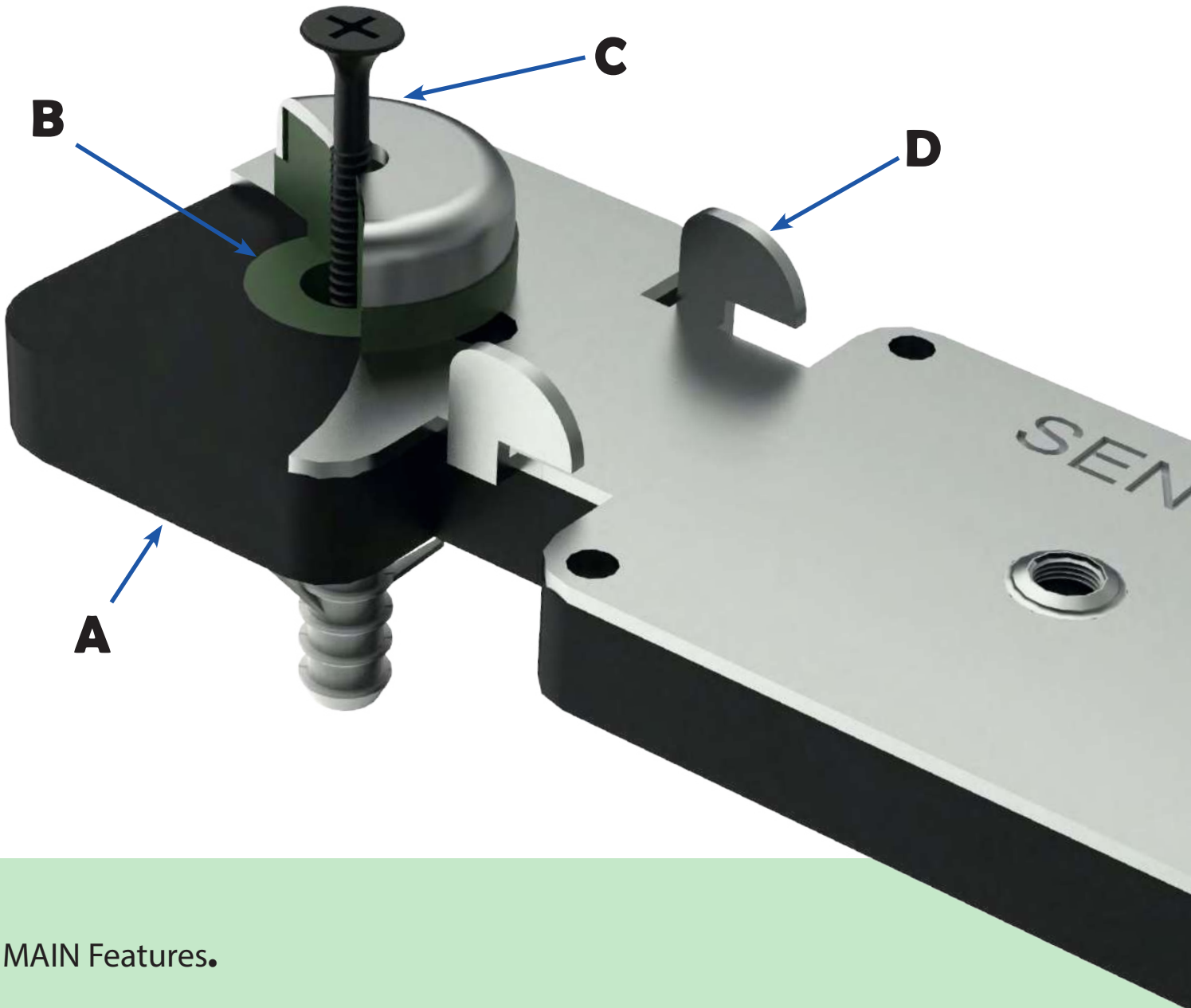

MAIN Features.

The "**FTD/OMEGA**" acoustic support has the advantage of incorporating the quick catch called "**CLIP STOP (D)**", providing quality and performance to the different finishes. It is an ultra fast anchorage for the support of acoustic walls by means of galvanized steel profiles, type **MAESTRA OMEGA**.

(Only we manufacture it).

Components:

A **BEC-10 sheet**; is a microcellular acoustic template made of **CAU EPDM 130 RE-42**. This favours a better settlement of the shock absorber with respect to the wall, absorbing any small imperfections that the original surface of the wall may present, in addition to providing optimal behavior in the range of **medium / high frequencies (Hz)**.

*SENOR acoustic insulators.

A shock absorber designed for
ACOUSTIC WALL PANELS.



Patented
P.T. 201531558 (b)

System A: "TC-4/GPN"

Load between: **3-25 Kg.**

Resonance Frequency **7 to 15 Hz.**

B TC 4/GPN, renewed polymer with raised neck. It avoids the contact between fixing-screw (**F**) and metal components (**C** and **E**). It also provides a perfect settlement and optimal behavior in the range of **medium / high frequencies (Hz)**.

System B: "TC-4/GPN"

Loads between **5-25 Kg**.

Resonance frequency **7 to 15Hz**.

C Bowl-shaped leveller, made of laminated steel type **DC04**, pressed according to standard **EN 10131**. with an edge thickness of 1.5 mm.

This design allows to increase the mechanical resistance of the piece and guarantee the fixing process.

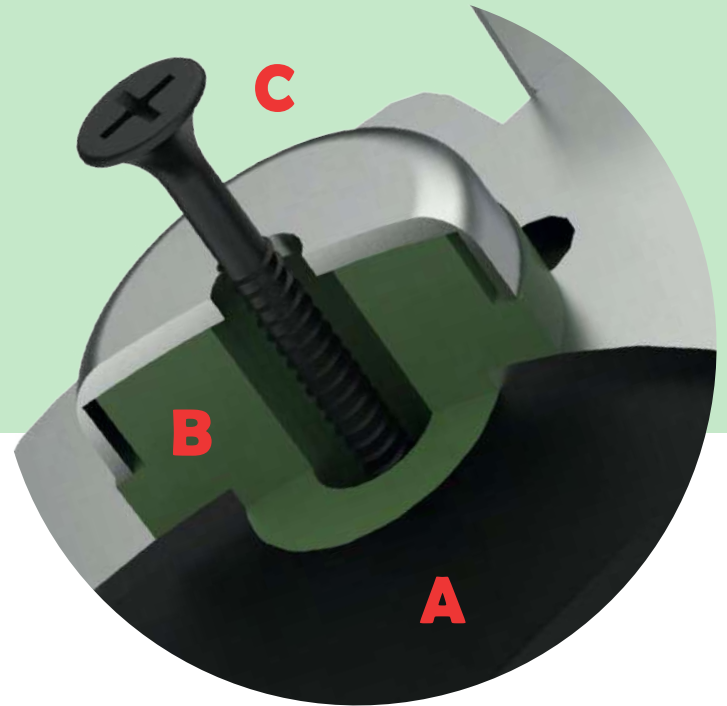

D CLIP STOP, is a single piece, a **clip** and a profile attached. Screws are a thing of the past. With **SENOR** and the **FTD/OMEGA**, innovation is assured. Speed and safety are already possible, especially in tight spaces.

E FTD OMEGA (E) wall panel, made of high performance galvanized steel **Dx54d + Z140** with an edge thickness of 1.5 millimeters. It provides rigidity to the system and axial compression in both directions of the elastic components of the product.

Ref. FTD OMEGA



*SENOR acoustic insulators.

F SAFETY DEVICE

formed by a central steel (**Screw**) and a metallic circular support (**CN**). In case of fire the polymer disappears, but the mechanical fixation remains.

System registered with the Spanish Patent and Trademark Office.

A shock absorber designed for ACOUSTIC WALL PANELS.

D

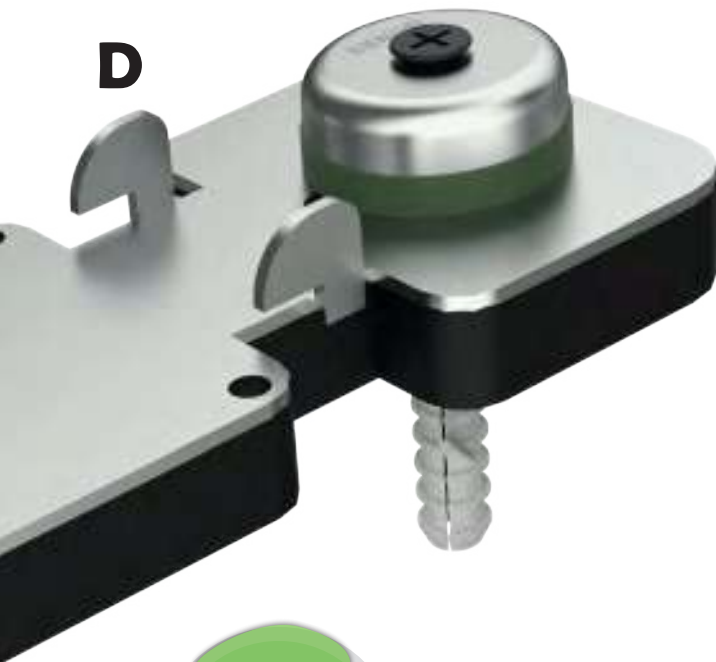

Patented
P.T. 201531558 (b)

Optimal performance.

When we excite an acoustic treatment and it begins to vibrate, it generates a swinging movement.

Therefore, we must place a shock absorber that allows axial compression in both directions.

The **FTD OMEGA** model incorporates a **"PATENTED"** movement and translation control system, which allows the FTD (**E**) wall-mount plate to move freely in both directions, that is, when the shock absorber is fixed to the wall with screws, it is fully attached to the facing, allowing the steel wall-mount plate to be completely free, being able to compress the polymer, both internally and externally. The steel screw (**F**) allows restricting degrees of freedom and favoring axial movement.

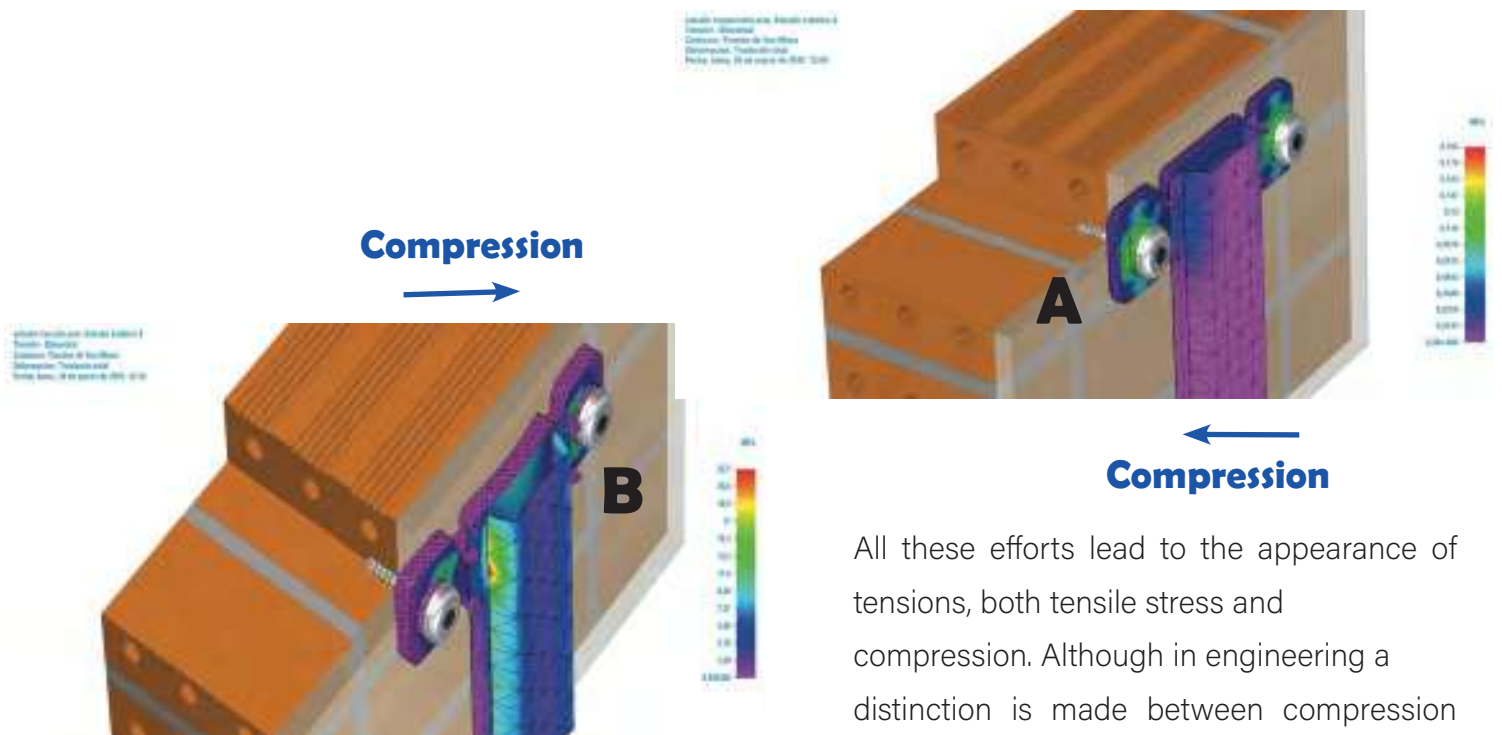

All these efforts lead to the appearance of tensions, both tensile stress and compression. Although in engineering a distinction is made between compression effort (axial force) and compressive strenghts.

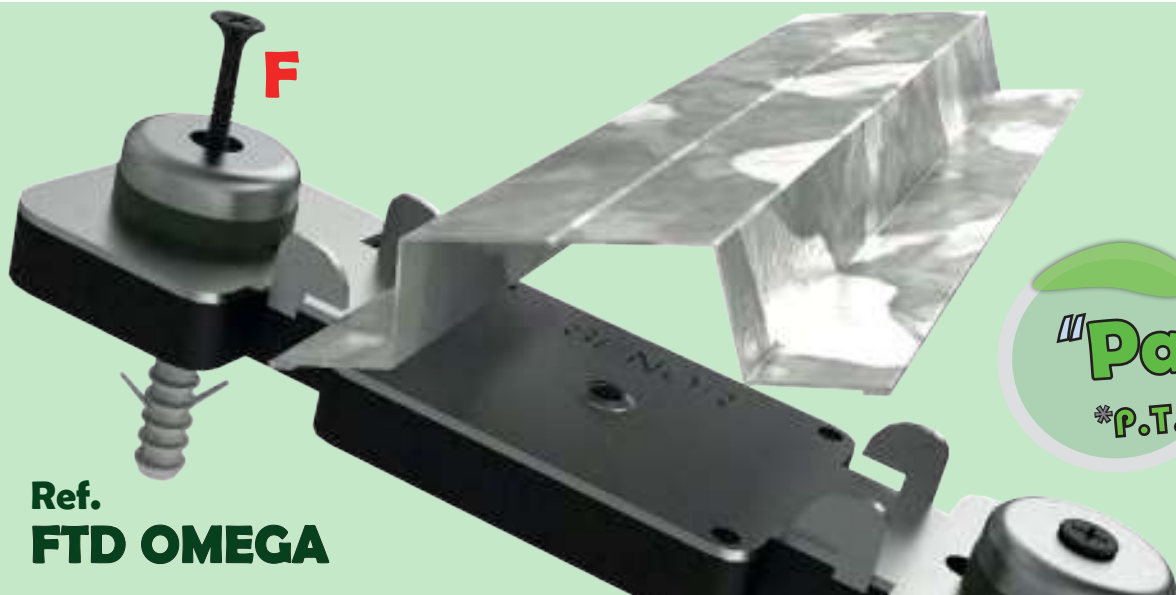

Ref.
FTD OMEGA

*SENOR acoustic insulators.

LABORATORY tests. UNE-EN ISO 10846-1:2009

Acoustics and vibrations. Laboratory measurement of the vibro-acoustic transfer properties of elastic elements.

IMPACT testing machine.



Snapshot of the test.



Obtained Results.

Test machine

Go back home menu...

FTD OMEGA 2020
1

Description

E.LABORATORIO P.TRANSFERENCIA/UNE-EN ISO 10846

realizada en Máquina C

Position [117,031 mm]

▼ -3,927 mm ● -5,461 mm ▲ -7,217 mm

Force [5,00 Kg ... 25,00 Kg]

▼ 3,00 Kg ● 12,58 Kg ▲ 24,30 Kg

Speed [0,030 mm/s]

▼ -0,150 mm/s ● -0,011 mm/s ▲ 0,001 mm/s

Frequency [15,00 Hz ... 50,00 Hz]

▼ 15,00 Hz ● 25,82 Hz ▲ 50,00 Hz

Attenuated Vibration [Oscillation de 10,00 mm]

▼ -127,3% ● 86,8% ▲ 97,8%

Natural frequency obtained [According to deformation mm]

▼ 12,50 Hz ● 8,82 Hz ▲ 7,35 Hz

Jefe de Laboratorio	Responsable de Ensayo
David Muñoz López	Manuel Montoro Muñoz

- Los resultados del presente informe conciernen, única y exclusivamente, a las muestras sometidas a ensayo.
- Queda totalmente prohibida la reproducción parcial del presente documento, salvo consentimiento escrito de **SEÑOR**.

⌚ 07:46 cycle 3.564.296

Kg
🖨️
↔️

Position

-6,337 mm

Force

17,00 Kg

Speed

-0,001 mm/s

Frequency

50,00 Hz

Attenuated vibration

97,4 %

Received **0,9 mm/s**
Issued **32,8 mm/s**

Natural frequency obtained [According to deformation mm]

● 8,02 Hz

▶ 1X

13:50:58
10 ago. 2020

*SENOR acoustic insulators.

LABORATORY TEST: UNE-EN ISO 10846-1:2009

Acoustics and vibrations. Laboratory measurement of the vibro-acoustic transfer properties of elastic elements.

"GRAPH 1"



"GRAPH 2"

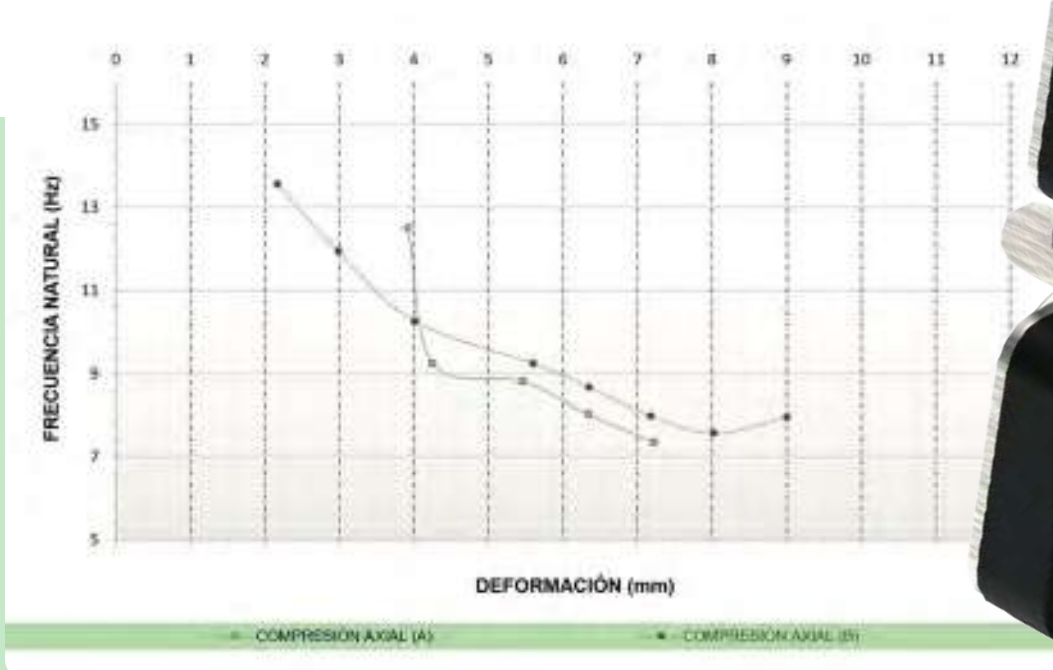

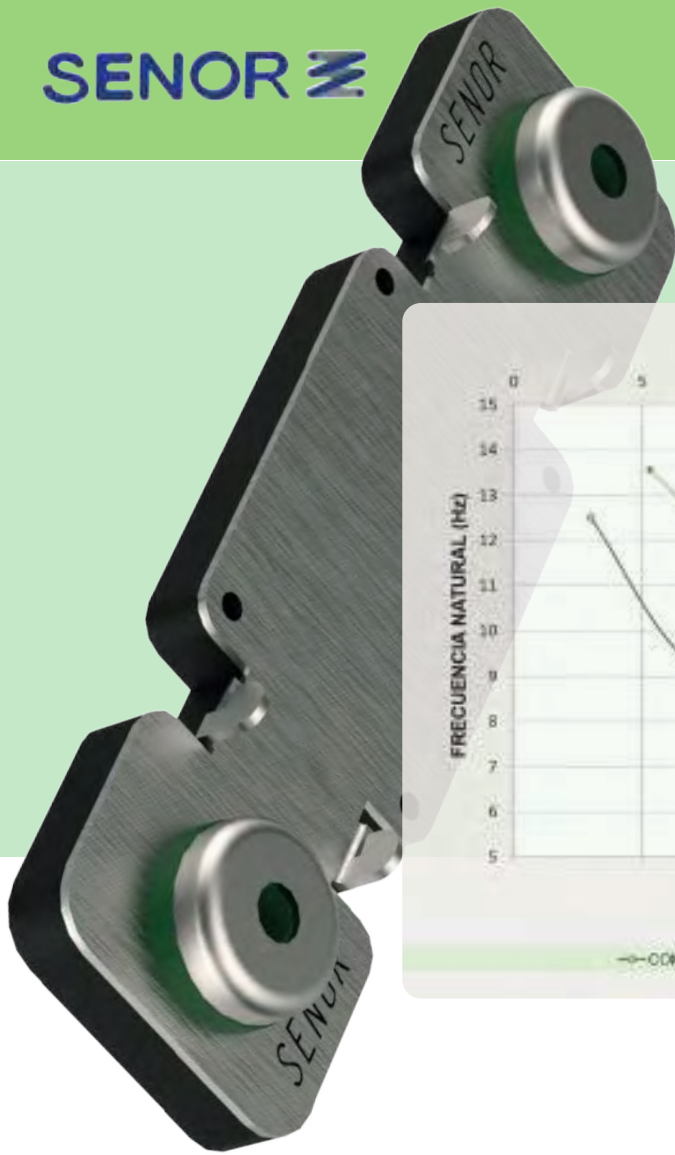

"GRAPH 3"

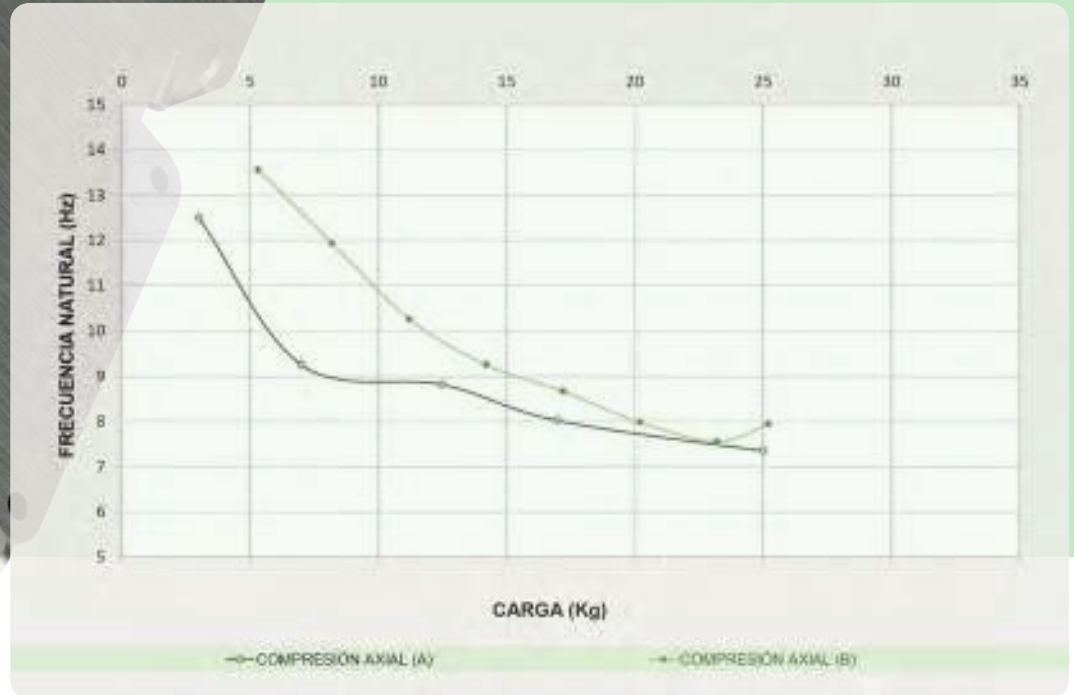

A shock absorber designed for ACOUSTIC WALL PANELS.

Product measurements

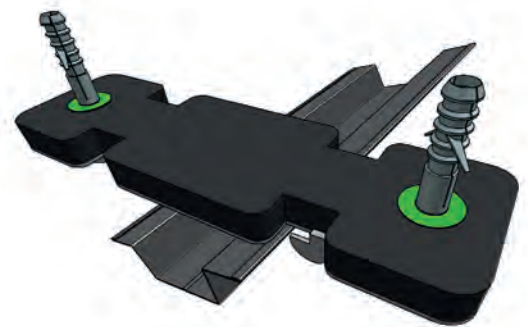
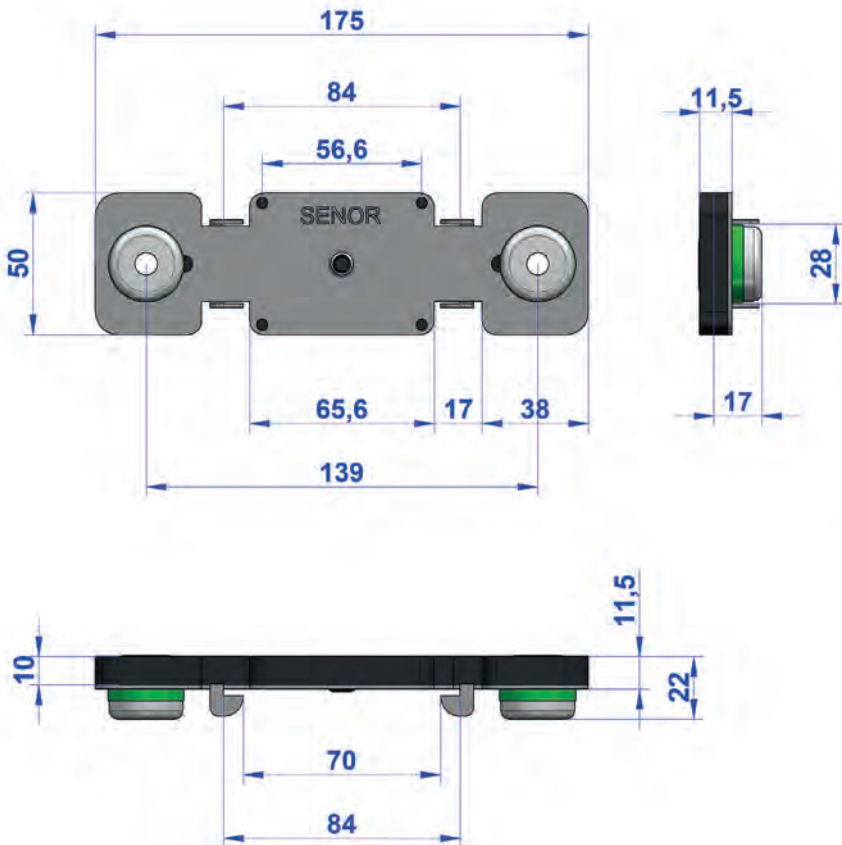

Ref. **FTD OMEGA**

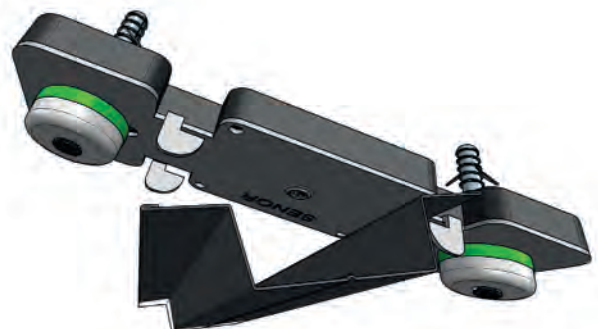

*SENOR acoustic insulators.



A shock absorber designed for
ACOUSTIC WALL PANELS.

ISO 9001:2015



Patented
P.T. 201531558 (6)



Ref.
FTD OMEGA

*SENOR acoustic insulators.

CERTIFICATE OF COMPLIANCE

SENOR certifies.

All our products in the construction range for the suspension of acoustic internal partition wall lining “**FTD/OMEGA**” have an optimal lifespan of 10 years; provided that the installation is carried out under normal environmental conditions and are not either exposed to chemical components that could degrade the product.

SENOR; declares under its responsibility that the following components of anti vibration suspension for false acoustic ceilings in buildings strictly comply with the technical sections of assembly and application appeared in the technical documentation of the product.



Warning **Important information**

SENOR”; reserves the right to make changes in specifications at any time without prior notice. It is a responsibility of the user to use the latest and updated version of the product data sheets. A copy of which will be available on request. This information and, in particular, relative recommendations to the application and final use of the product, are given in good faith, based on “**SENOR**” knowledge and experience of its products, provided that they are correctly installed in normal circumstances and within its useful life.

PROJECT MANAGER: David Muñoz “**SENOR**”