

## 7600/Tb2

### RUBBER WALL MOUNT WITH DOUBLE FASTENING TO CONNECT TWO SELF-SUPPORTING STRUCTURES (ACOUSTIC PARTITION WALL SYSTEM)

This model is a **RUBBER** wall mount devised to provide quality to any given acoustic system. Its main function is to connect two self-supporting structures providing elasticity in order to attenuate sound frequencies and vibrations.

The **SE-7600/Tb2** has a **PATENTED** control system which allows the steel brackets to be moved in both directions. By fixing both sides with screws, the metal bracket can be moved and the polymer is compressed in both directions.

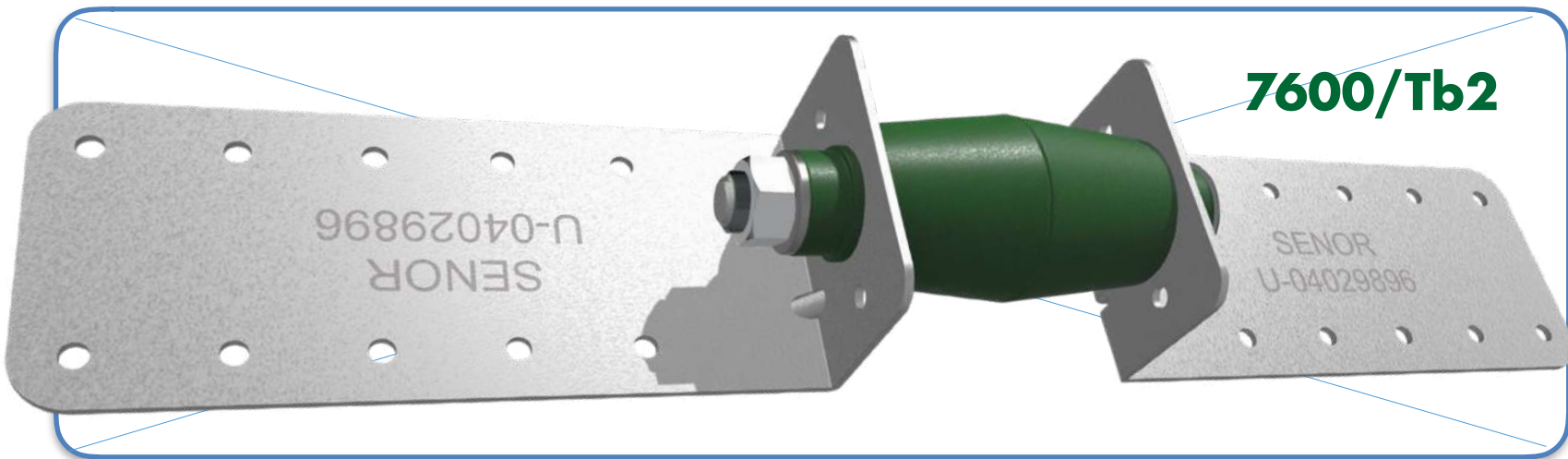
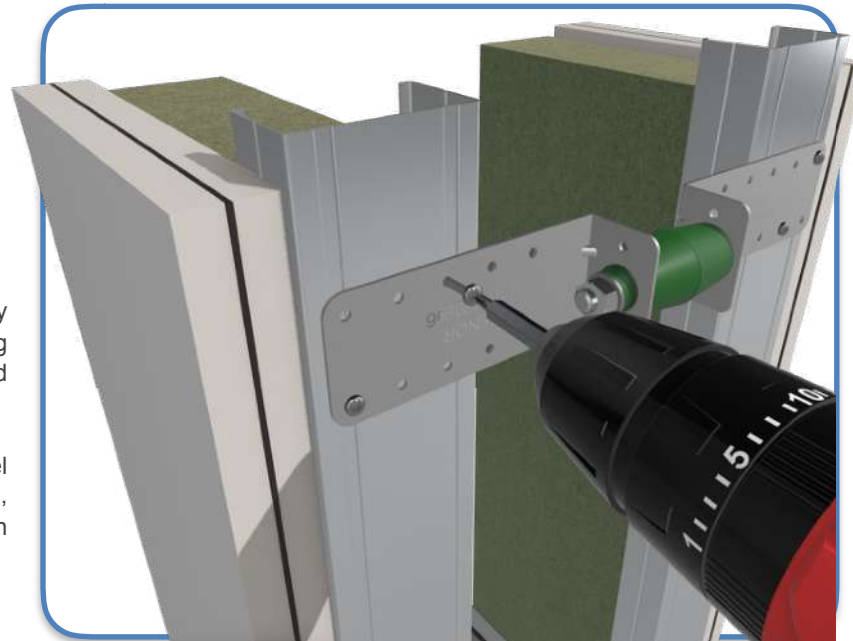

**The steel brackets:** made according to the Standard **EN 10204/DIN50049 / ISO404**. Transformation according to Iron and Steel Standard **EN 10346:2015**.

Quality: **DX51D+Z275 NA C. 275 g/m<sup>2</sup>**.

- **Thickness:** 1,5 mm (more thickness, more resistance).



**I+D+i**

\*This product has been registered in the **Spanish Patents and Trademarks Office**.

REF	COLOUR	THICKNESS (mm)	CHANNEL	LOAD (kg) MIN-MAX	PACKING
SE-7600/Tb2		1,5	Double stud	5 - 32	25

**Get more soundproofing!** With this product, there is more distance between studs. Therefore, you will be able to enlarge the air chamber with excellent results. **Get rid of noises!**

- The polymer is named **KRAIBURG-TPE** (tested according to the Standard **UNE-EN ISO 10846-1:2009**).

✓ Resonance frequency: **7-15 Hz**.

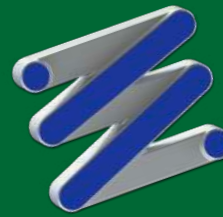

freq. (Hz)	R(dB)	R(dB)
50	17	
63	24	21
80	42	
100	49	
125	56	53
160	64	
200	71	
250	77	74
315	82	
400	87	
500	91	89
630	95	
800	98	
1000	102	101
1250	105	
1600	108	
2000	110	110
2500	111	
3150	107	
4000	126	112
5000	138	

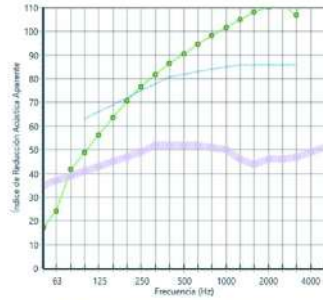

Rw 82 dB  
C -6 dB  
Ctr -14 dB

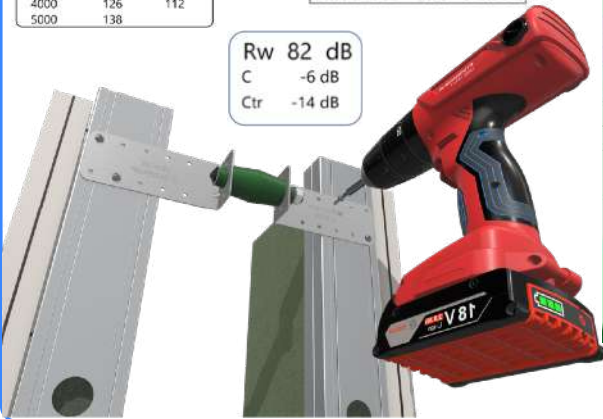

## Laboratory test UNE-EN ISO 10846-1:2009

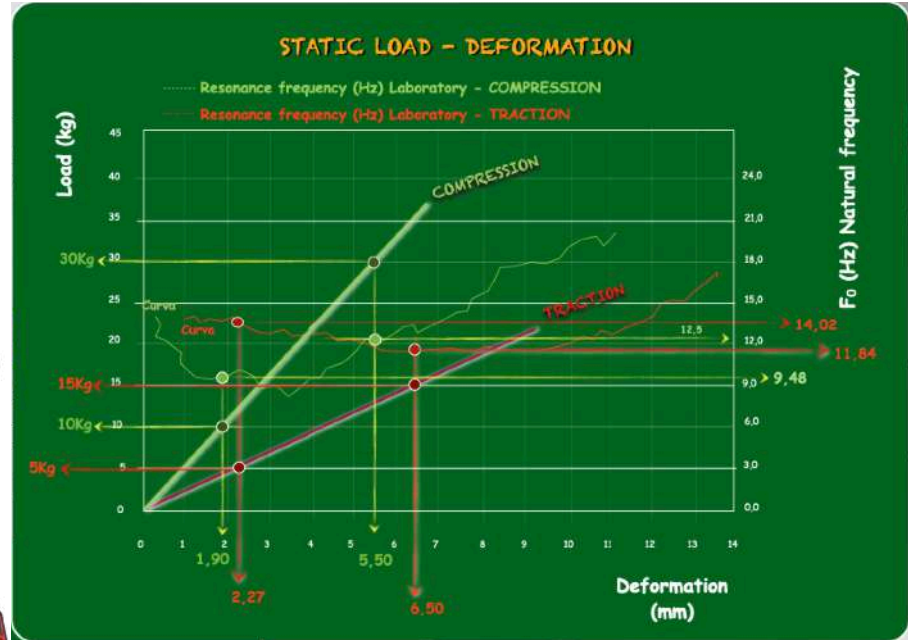

### Axial compression results

LOAD (Kg)	DEFORMATION (mm)	RESONANCE FREQUENCY (Hz)	SWEEP (Hz)		SOUNDPROOFING LEVEL (%)	
10	1,90	9,48	25	50	83,21	96,27
20	3,75	8,68	25	50	86,29	96,89

### Axial tensile results

5	2,27	14,02	25	50	54,12	91,47
10	4,22	11,92	25	50	70,58	93,97
15	6,50	11,84	25	50	71,08	94,06



### Data sheet

TC4GPN (GP/FG Series)

THERMOLAST® K

#### Product properties

Name TC4GPN  
Series GP/FG  
Colour / RAL DESIGN Natural

#### Mechanical properties

Hardness	39 <sup>+</sup> +/- 5 <sup>+</sup> ShoreA	DIN ISO 7619-1
Density	1.100 g/cm <sup>3</sup>	DIN EN ISO 1183-1
Tensile strength <sup>1</sup>	6.5 MPa	DIN 53504/ISO 37
Elongation at break <sup>1</sup>	800 %	DIN 53504/ISO 37
Tear resistance	14.0 N/mm	ISO 34-1 Methode B (b)(Graves)
CS 72 h/23 °C	12 %	DIN ISO 815-1 Method A
CS 24 h/70 °C	23 %	DIN ISO 815-1 Method A
CS 24 h/100 °C	59 %	DIN ISO 815-1 Method A

<sup>1</sup> Deviating from ISO 37 standard test piece S2 is tested with a traverse speed of 200 mm/min.

All values published in this data sheet are rounded average values.

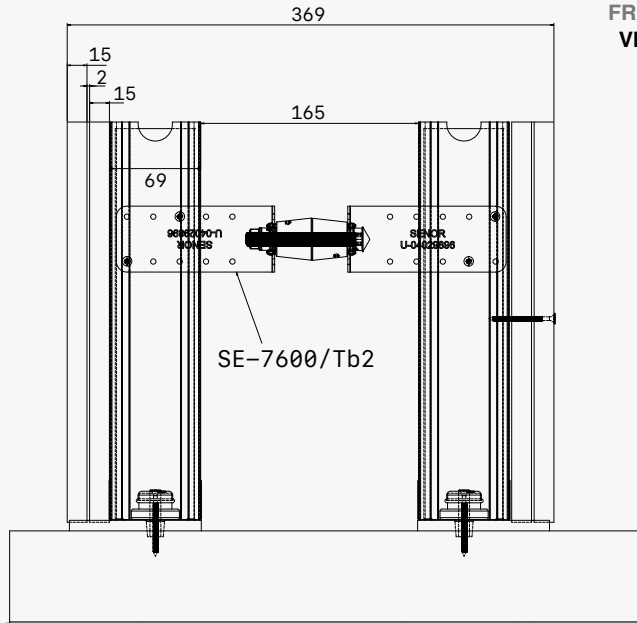

FRONT  
VIEW

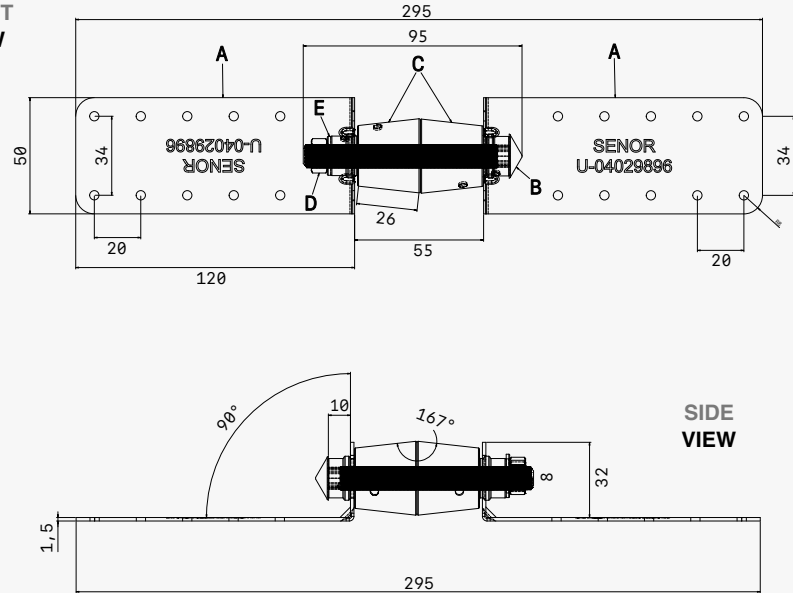

3D  
VIEW

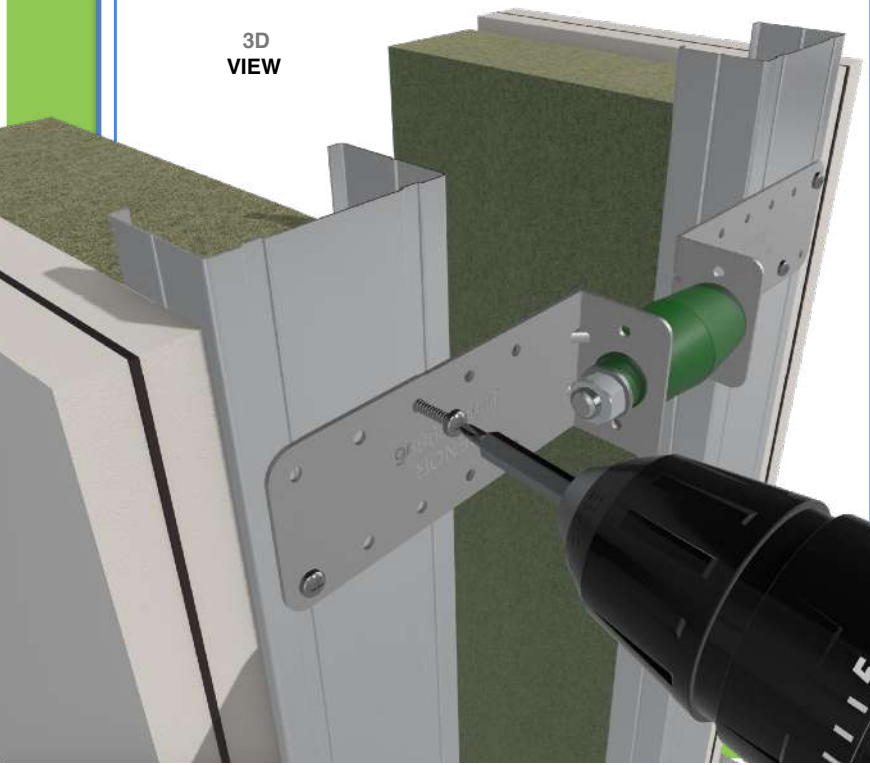

### MATERIALS

This acoustic wall mount is composed of:

- A: 2x **Metal bracket 1,5x50x120** made of galvanized steel according to The Standard **EN 10204/DIN50049/ISO404**. Transformation according to iron and steel Standard **EN 10346:2015**. Steel quality **DX51D+Z275 MA**. Zinc covering 300 g/m<sup>2</sup>.
- B: 1x **Steel screw 8x95**: Zinc Plated Cr+3 The Standard **DIN603**.
- C: 2x The polymer: **KRAIBURG-TPE / TC4GPN**. **Hardness: 39 +/- 5° SHORE A**. **Colour: Green**. Hardness according to the Standard **ISO 48-4** o **DIN ISO 7619-1**.
- D: 1x **-Standard nut DIN-934 A2**: made of zinc steel for **metric 8**.
- E: 1x **- Dock washer DIN-9021**: made of zinc steel for **metric 8**.

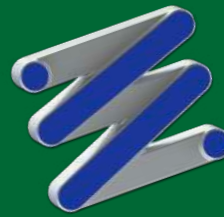

# Ref. SE-7600/Tb2

## Note

### POSITIONS

This acoustic mount is devised to work in both directions: axial compression to the outside of the partition wall and axial compression inside the partition wall.

## Ref. SE-7600/

### AXIAL COMPRESSION INSIDE THE PARTITION WALL

Loads: 5 kg up to 32 kg (maximum load).

Resonance frequency: 7-15 Hz.

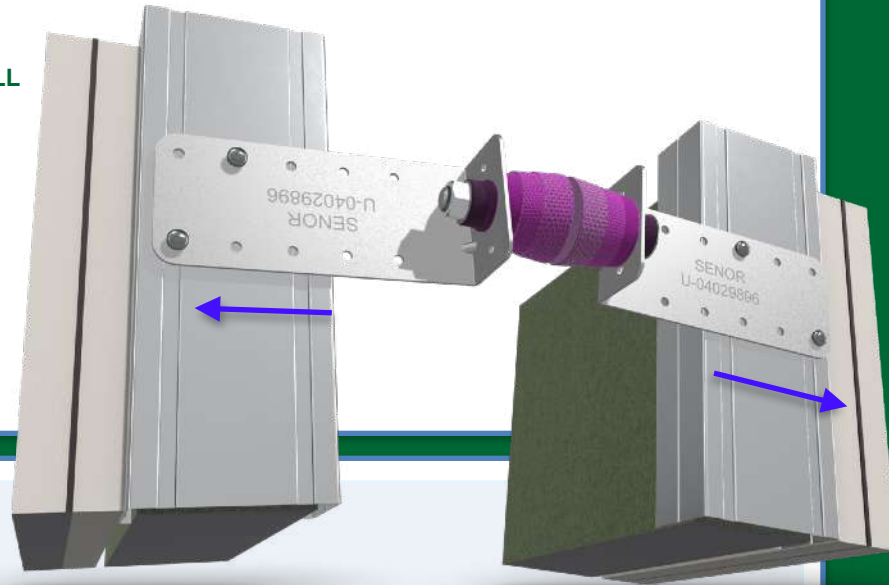

## Ref. SE-7600/Tb2

### AXIAL COMPRESSION TO THE OUTSIDE OF THE PARTITION WALL

Loads: 5 kg up to 15 kg (maximum load).

Resonance frequency: 7-15 Hz.

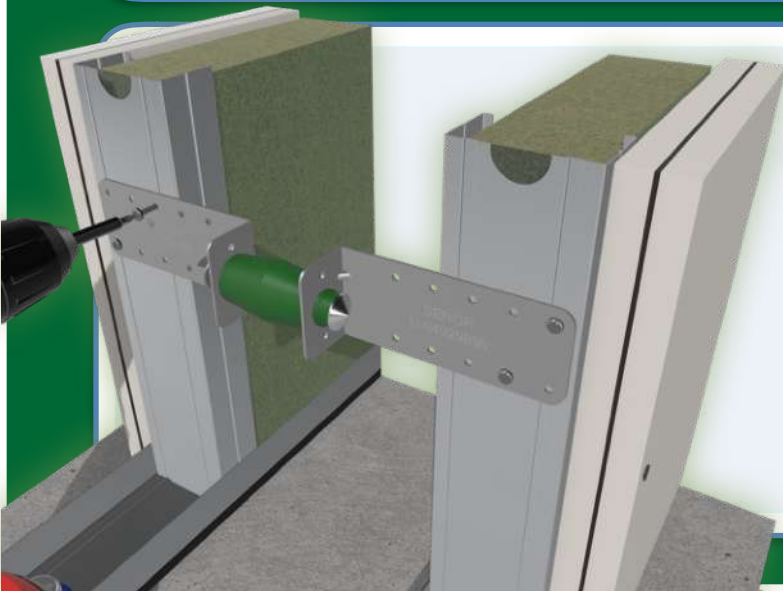





## Ref. SE-7600/Tb2

### SAFETY SYSTEM

#### Ref. SE-7600/Tb2

Inside the rubber, there is a steel shaft to get **maximum safety** in case of **fire**. The polymer is disintegrated but, due to the steel shaft, the fastening remains even if the acoustic system is heated to a high temperature (120°).

**I+D+i**

\*This product has been registered in the **Spanish Patents and Trademarks Office**.



**STEEL SHAFT**

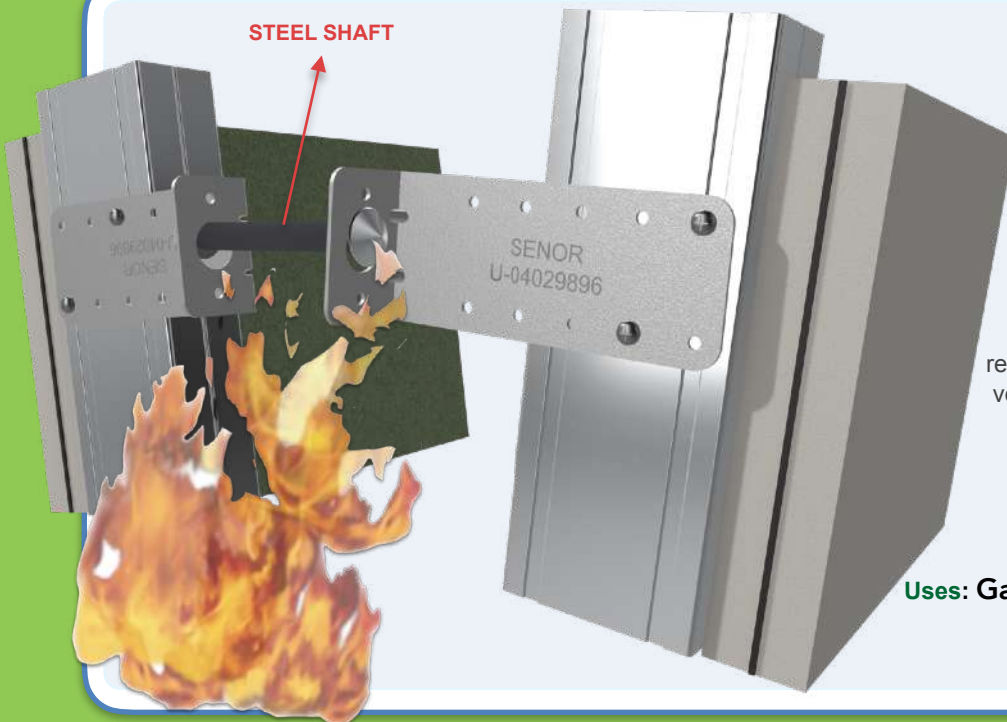

SENOR certifies

#### Ref. SE-7600/Tb2

**SENOR** reserves the right to make changes in specifications at any time without prior notice. It is a responsibility of the user to use the latest and updated version of the product data sheet. A copy of which will be available on request.

**The Standard: UNE-EN 37-507-88**

**Uses: Galvanized coatings on fabricated iron and steel articles**

## 7602/Tb2

### RUBBER WALL MOUNT WITH DOUBLE FASTENING TO CONNECT TWO SELF-SUPPORTING STRUCTURES (ACOUSTIC PARTITION WALL SYSTEM)

This model is a **RUBBER** wall mount devised to provide quality to any given acoustic system. Its main function is to connect two self-supporting structures providing elasticity in order to attenuate sound frequencies and vibrations.

The model **SE-7602/Tb2** has a **PATENTED** control system which allows the metal brackets to be moved in both directions. By fixing both sides with screws, the metal bracket can be moved and the polymer is compressed in both directions.

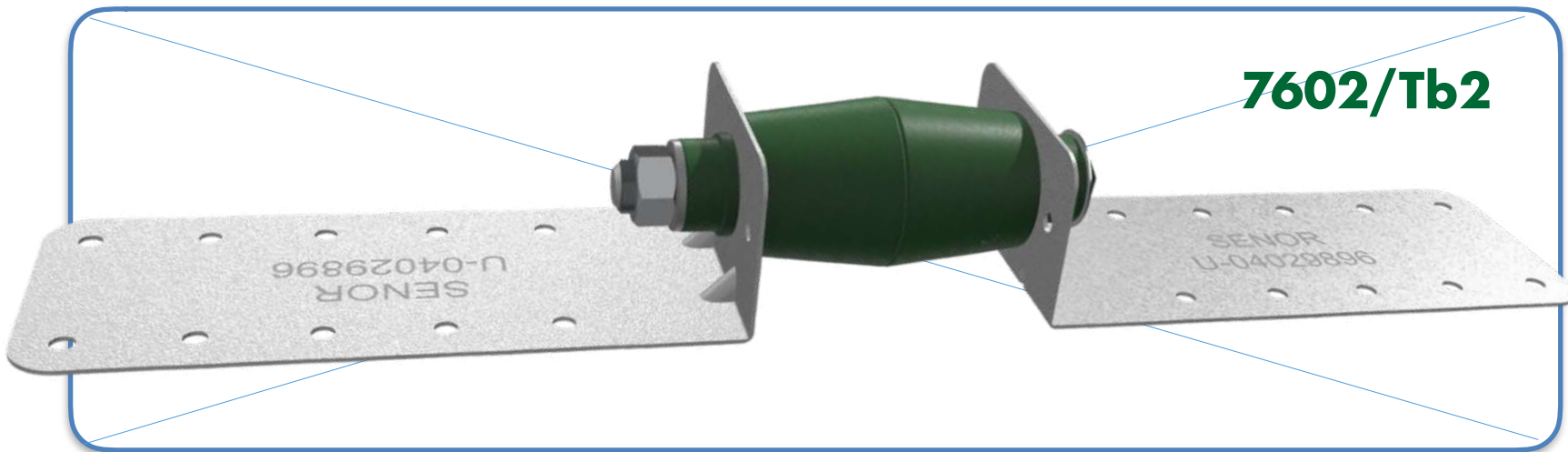
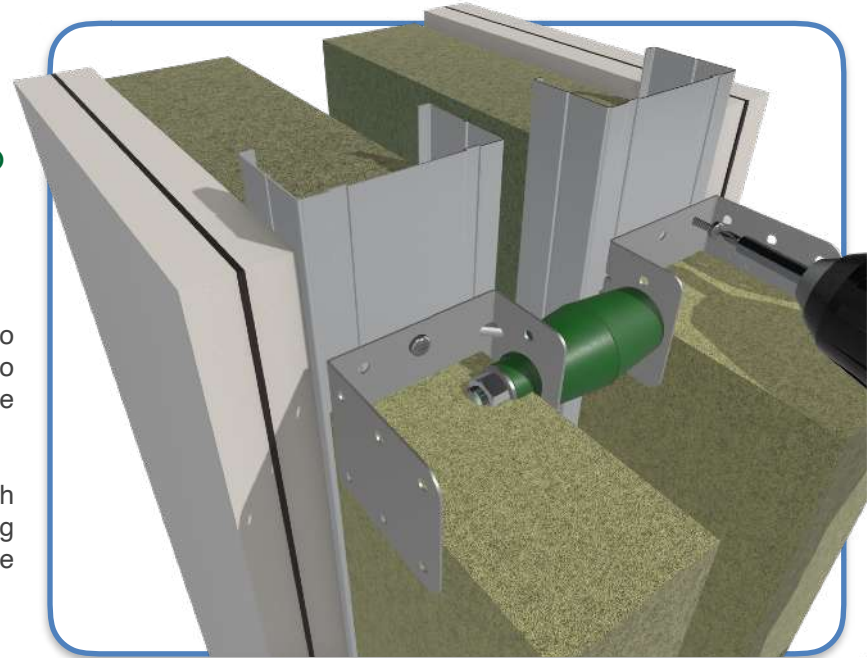

**The steel bracket:** made according to the Standard **EN 10204/DIN50049 / ISO404**. Transformation according to Iron and Steel Standard **EN 10346:2015**.

Quality: **DX51D+Z275 NA C. 275 g/m<sup>2</sup>**.

- **Thickness:** 0,8 mm

**I+D+i**

\*This product has been registered in the Spanish Patents and Trademarks Office.

SCAN ME



REF	COLOUR	THICKNESS (mm)	CHANNEL	LOAD (kg) MIN-MAX	PACKING
SE-7602/Tb2		0,8	Double stud	5 - 32	25

Bend the bracket with your hand!

By bending the bracket, the air chamber can be reduced. In addition, the bracket allows the deadening material to be held.

- The polymer is named **KRAIBURG-TPE** (according to the Standard **UNE-EN ISO 10846-1:2009**).

✓Resonance frequency: **7-15 Hz**.

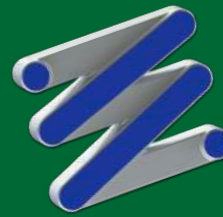

## Laboratory test UNE-EN ISO 10846-1:2009

frecuencia (Hz)	Ri(dB)	Ri(dB)
50	28	
63	35	31
80	41	
100	47	
125	52	50
160	57	
200	62	
250	67	65
315	70	
400	73	
500	76	76
630	79	
800	82	
1000	85	85
1250	87	
1600	89	
2000	88	81
2500	77	
3150	80	
4000	86	84
5000	92	

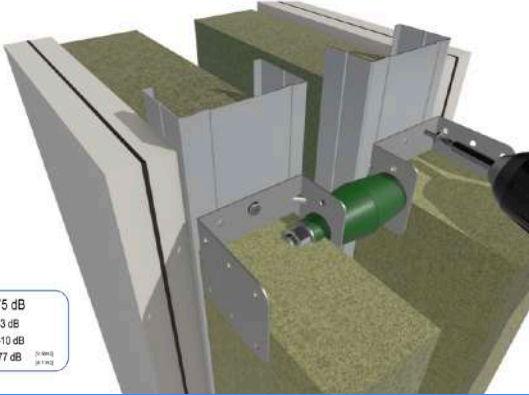
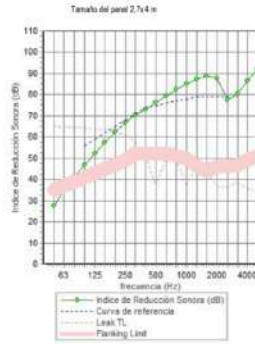

Rw 75 dB  
C -3 dB  
C<sub>p</sub> -10 dB  
D<sub>nT,w</sub> 77 dB

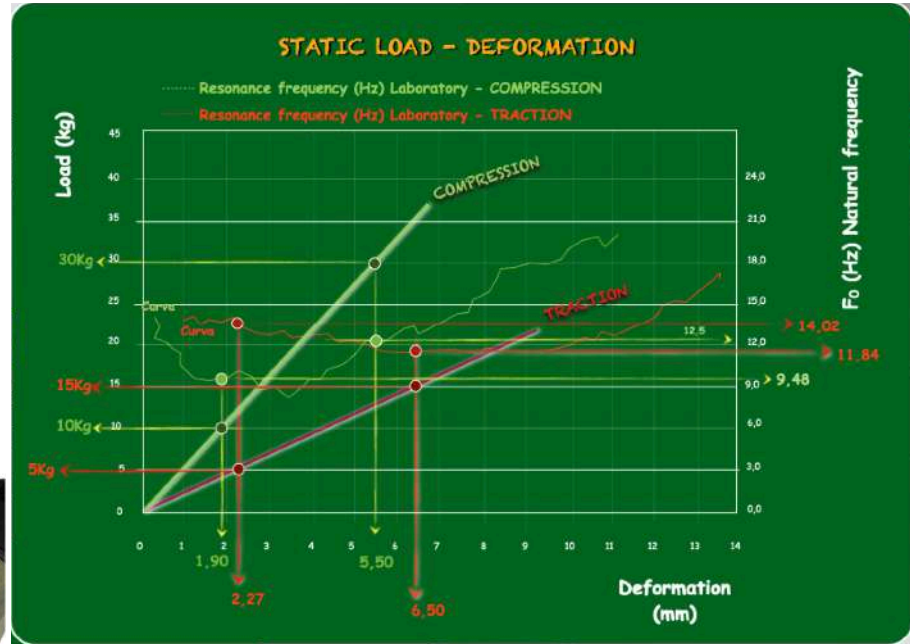

### Axial compression results

LOAD (Kg)	DEFORMATION (mm)	RESONANCE FREQUENCY (Hz)	SWEEP (Hz)		SOUNDPROOFING LEVEL (%)	
10	1,90	9,48	25	50	83,21	96,27
20	3,75	8,68	25	50	86,29	96,89

### Axial tensile results

5	2,27	14,02	25	50	54,12	91,47
10	4,22	11,92	25	50	70,58	93,97
15	6,50	11,84	25	50	71,08	94,06



### Data sheet

TC4GPN (GP/FG Series)

THERMOLAST® K

#### Product properties

Name TC4GPN

Series GP/FG

Colour / RAL DESIGN Natural

#### Mechanical properties

Hardness 39<sup>+</sup> ± 5<sup>+</sup> ShoreA DIN ISO 7619-1

Density 1.100 g/cm<sup>3</sup> DIN EN ISO 1183-1

Tensile strength<sup>1</sup> 6.5 MPa DIN 53504/ISO 37

Elongation at break<sup>1</sup> 800 % DIN 53504/ISO 37

Tear resistance 14.0 N/mm ISO 34-1 Methode B (b)(Graves)

CS 72 h/23 °C 12 % DIN ISO 815-1 Method A

CS 24 h/70 °C 23 % DIN ISO 815-1 Method A

CS 24 h/100 °C 59 % DIN ISO 815-1 Method A

<sup>1</sup> Deviating from ISO 37 standard test piece S2 is tested with a traverse speed of 200 mm/min.

All values published in this data sheet are rounded average values.



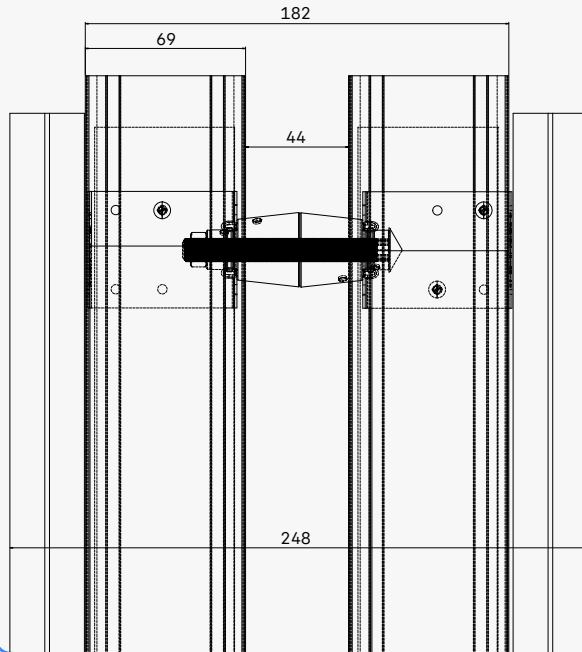

FRONT  
VIEW

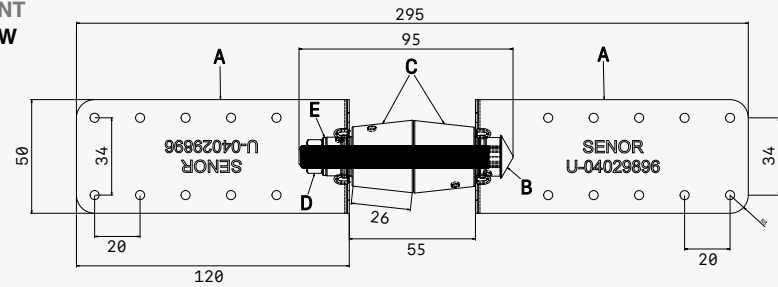

STEEL BRACKET BENT BY HAND

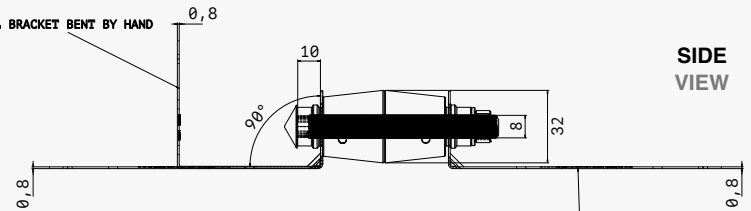

SIDE  
VIEW

NON-BENT STEEL BRACKET



3D  
VIEW

### MATERIALS

This acoustic wall mount is composed of:

- A: 2x **Metal bracket 0,8x50x120** made of galvanized steel according to The Standard **EN 10204/DIN50049/ISO404**. Transformation according to iron and steel Standard **EN 10346:2015**. Steel quality **DX51D+Z275 MA**. Zinc covering 300 g/m<sup>2</sup>
- B: 1x **Steel screw 8x95**: Zinc Plated Cr+3 Standard **DIN603**.
- C: 2x **The polymer: KRAIBURG-TPE / TC4GPN**. Hardness: 39 +- 5° SHORE A. Colour: **Green**. Hardness according to the Standard **ISO 48-4** o **DIN ISO 7619-1**.
- D: 1x - **Standard Nut DIN-934 A2** made of zinc steel for metric 8.
- E: 1x - **Dock washer DIN-9021** made of zinc steel for metric 8.



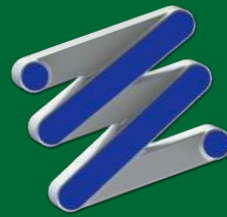

# Ref. SE-7602/Tb2

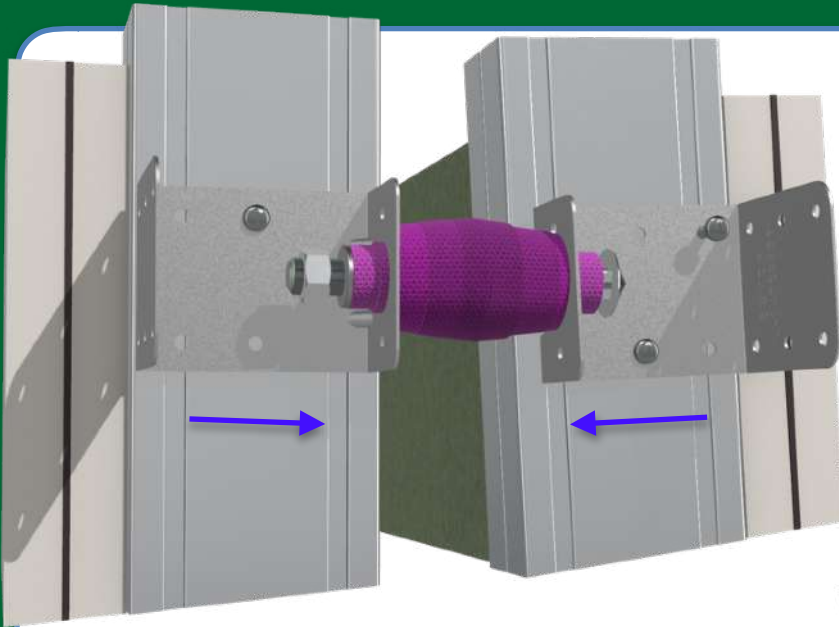

## Ref. SE-7602/Tb2

### AXIAL COMPRESSION INSIDE THE PARTITION WALL

Loads between 5 kg up to 32 kg (maximum load).

Resonance frequency: 7-15 Hz.

## Note

### POSITIONS

This acoustic mount is devised to work in both directions: axial compression to the outside of the partition wall and axial compression inside the partition wall.

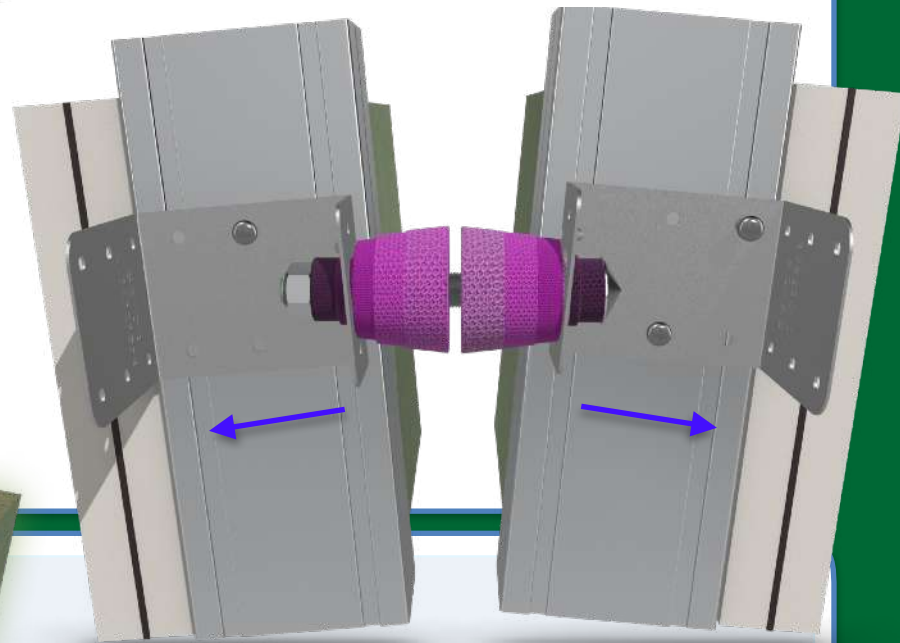

## Ref. SE-7602/Tb2

### AXIAL COMPRESSION TO THE OUTSIDE OF THE PARTITION WALL

Loads between 5 kg up to 15 kg (maximum load).

Resonance frequency: 7-15 Hz.

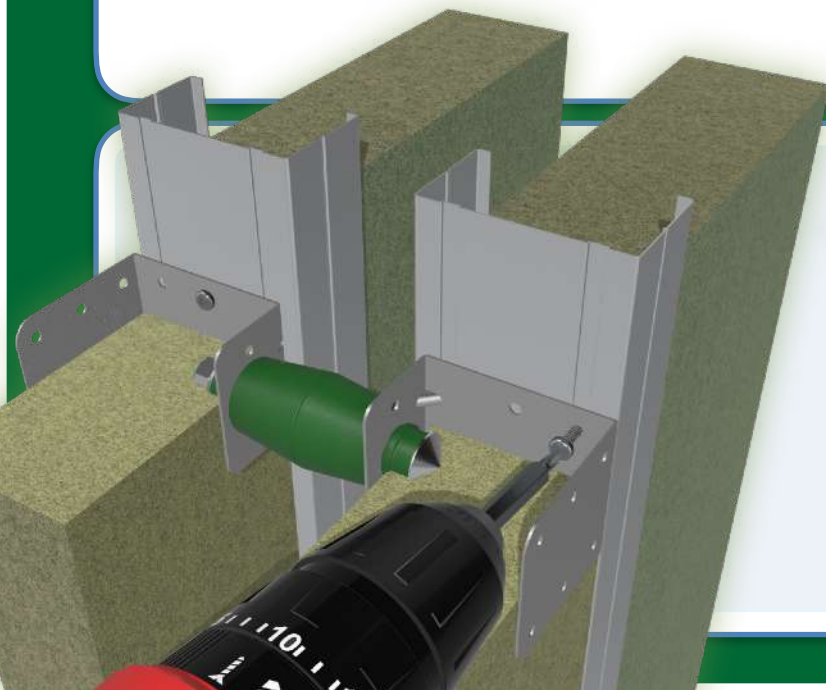



## SAFETY SYSTEM

### Ref. SE-7602/Tb2

Inside the rubber, there is a steel shaft to get **maximum safety** in case of **fire**. The polymer is disintegrated but, due to the steel shaft, the fastening remains even if the acoustic system is heated to a high temperature (120°).

**I+D+i**

\*This product has been registered in the Spanish Patents and Trademarks Office.



STEEL SHAFT

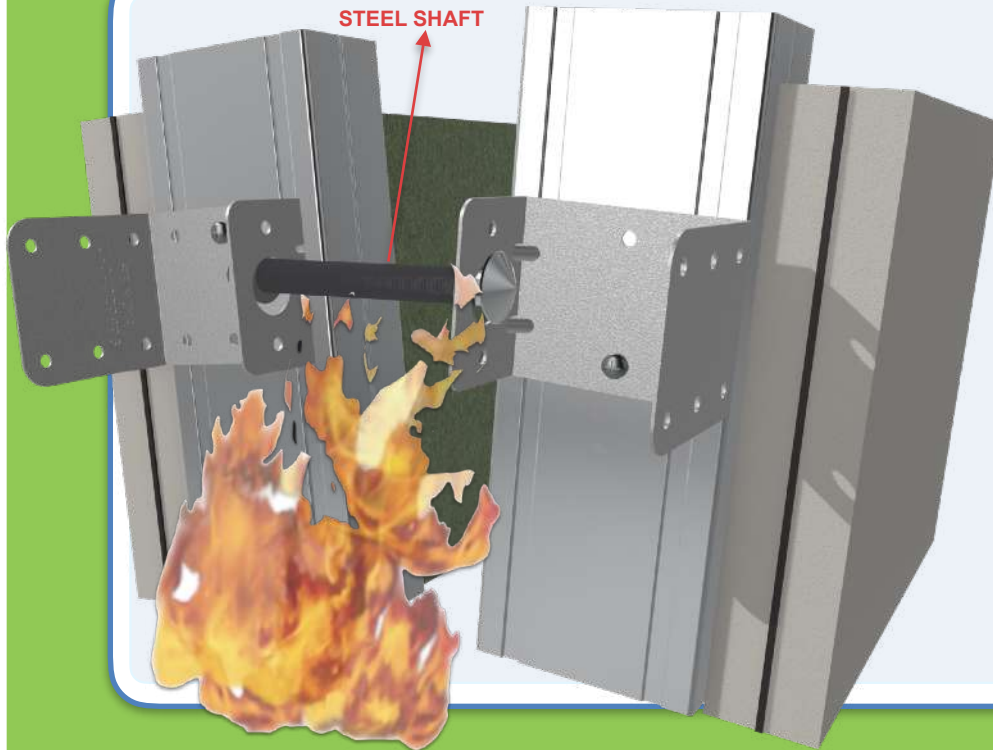

SENOR certifies

### Ref. SE-7602/Tb2

SENOR reserves the right to make changes in specifications at any time without prior notice. It is a responsibility of the user to use the latest and updated version of the product data sheet. A copy of which will be available on request.

**The Standard: UNE-EN 37-507-88**

**Uses: Galvanized coatings on fabricated iron and steel articles.**